

valentini.it

VALENTINI

VALENTINI

italian comfort

A story of excellence

Since 1954

63 anni di eccellenza, due generazioni che portano in tutto il mondo la cultura artigianale italiana. La famiglia Valentini è diventata oggi una realtà riconosciuta a livello internazionale nel settore dell'arredamento d'interni e, nel corso della sua storia, ha dato forma e vita a collezioni esclusive di divani, poltrone, tavolini, librerie e madie per un living completo, alle quali si aggiungono anche i letti imbottiti per la zona notte.

Tradizione e innovazione si incontrano, creano armonie di linee e volumi e permettono di vivere la casa nella sua totalità. Un'azienda che si rinnova ogni giorno, nella ricerca stilistica, creativa e tecnologica per apportare novità nel design, nella scelta dei materiali e nelle lavorazioni.

Valentini crea spazi da vivere e condividere.

63 years of excellence and two generations taking Italian craftsmanship to all corners of the world. The Valentini family has become an internationally recognised name in the interior furniture sector and, over the course of its history, has given form and life to exclusive collections including sofas, armchairs, tables, bookcases and cabinets to create a complete living space, with the addition of upholstered beds for the bedroom area. Tradition and innovation combine to create harmonies of form and shape, and allow you to live your home experience to the full. This is a company that reinvents itself on a daily basis, in a quest for new styles, creativity and technology to bring innovation to the design, choice of materials and techniques. Valentini creates spaces to experience and share.

Why choose Valentini?

Valentini segue tutte le fasi del processo produttivo e le realizza completamente all'interno dell'azienda, in un perfetto equilibrio tra innovazione tecnologica e capacità artigianale. Strutture solide, tessuti pregiati, pelli bovine selezionate, imbottiture diversificate dalle prestazioni straordinarie, confezionamenti rigorosi e funzionali sono le principali caratteristiche dell'altissima qualità italiana di Valentini.

Valentini monitors each stage of the production process, which is carried out exclusively within the company, with the perfect balance of technological innovation and artisan skill. Solid structures, luxurious fabrics, selected cowhide, diversified high-performing padding, and resistant and functional packaging are all key characteristics of the ultra-high Italian quality at Valentini.

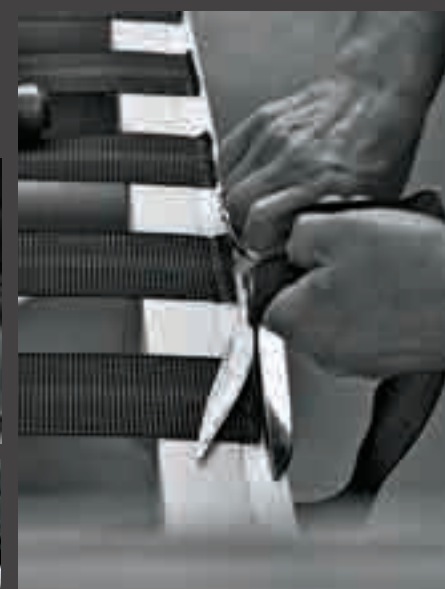



living in style

index

divani/ sofas

- 233 _ **artur**
- 035 _ **austin**
- 081 _ **bastian**
- 141 _ **box**
- 161 _ **charles**
- 009 _ **dylan**
- 201 _ **eduard**
- 123 _ **ernest**
- 111 _ **flower**
- 191 _ **gas**
- 181 _ **harry soft**
- 131 _ **hugo**
- 061 _ **jacob**
- 211 _ **james**
- 151 _ **kilt**
- 095 _ **lambert**
- 023 _ **norton**
- 171 _ **samuel**
- 071 _ **slim**
- 221 _ **wall**
- 047 _ **william**

poltroncine/ armchairs

- 245 _ **demetra**
- 247 _ **elle**
- 249 _ **gas**
- 243 _ **holly**
- 251 _ **isa**
- 253 _ **lea**

-
- 255 _ **pouf**
-



dylan

Un divano capace di assumere molte forme e di soddisfare diverse esigenze di comodità. Gli schienali sono facilmente ripiegabili: abbassati permettono un corretto sostegno della schiena, alzati diventano una comoda testiera. I movimenti esprimono il lato pratico di Dylan, i cuscini e le sedute sono la sua anima soft.

A sofa that takes on many forms, to satisfy different comfort needs. The backrests are easily foldable: when lowered, they correctly support your back; when raised they serve as a comfy headrest. The movable parts highlight the practical nature of the Dylan sofa, while the cushions and seats reveal its softer side.



dylan
comp. 2
bracciolo/ armrest
cm 33



Tre tipologie e misure di braccioli per scegliere comfort e design.
Three types and sizes of armrest: comfort and design.



Nel living la penisola mette d'accordo
stile e comodità.
The chaise end brings together style
and comfort in the living room.

dylan
comp.2
bracciolo/ armrest
cm 8



dylan
divano 4 posti/ four-seater sofa
pouf



Ad ognuno la sua comodità grazie
al poggiatesta pieghevole.
Each to their own idea of comfort
with this foldable headrest.



dylan

Le molteplici identità di Dylan gli consentono di assumere diverse forme e di assecondare tutte le esigenze. Il massimo della flessibilità in ogni singolo modello o composizione.

The many faces of Dylan mean it can take on different forms and provide a solution for every need. Maximum flexibility with every model and composition.



dylan
divano 3 posti/ three-seater sofa

Divani Sofa

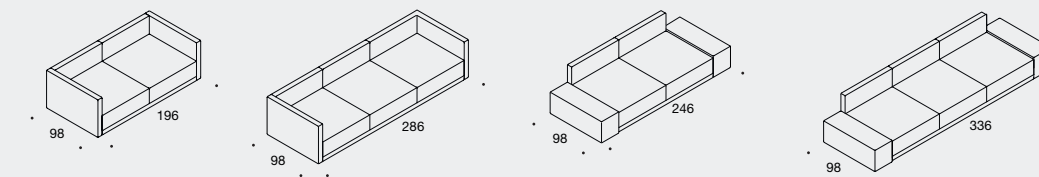

Elementi centrali Central elements

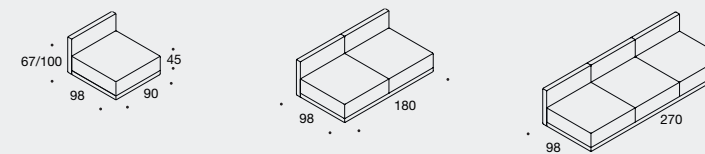

Elementi laterali Lateral elements

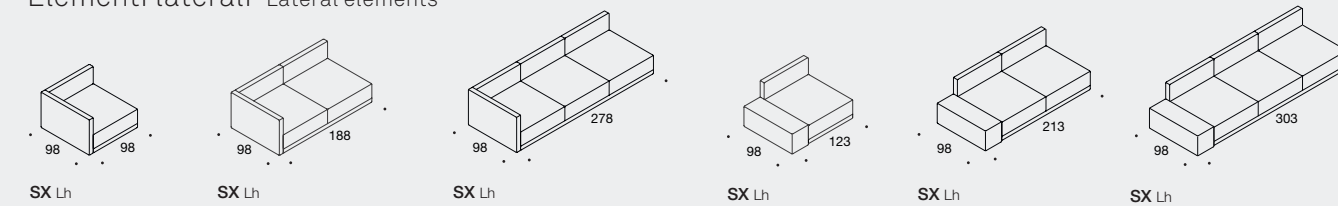

Chaise longue Chaise longue

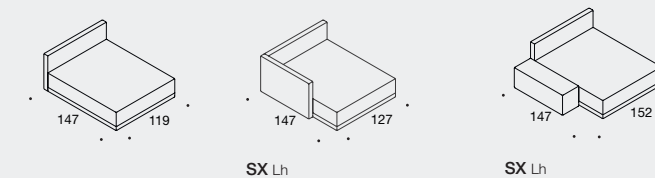

Pouf Pouf

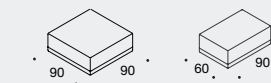

Libreria Bookcase

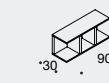

Cuscini Cushions



Schienale Arm back

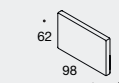

Composizione divani Sofas composition

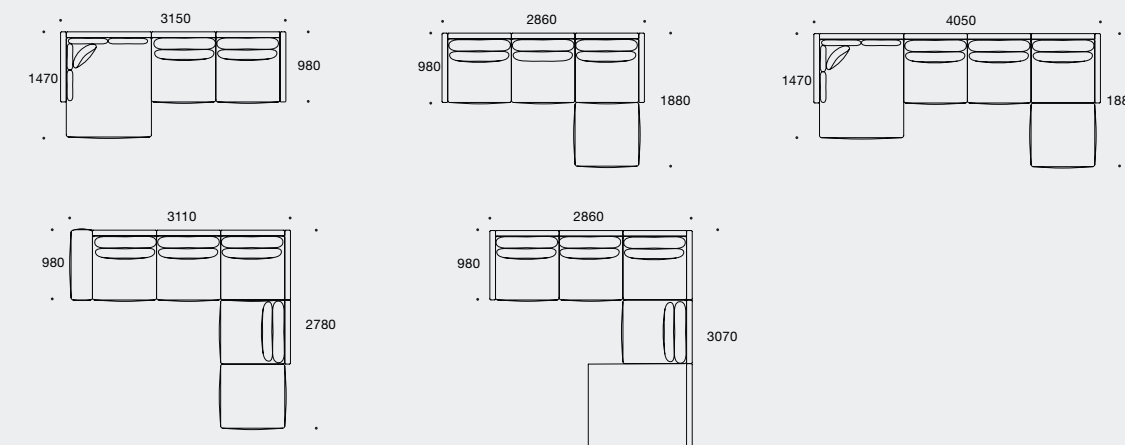

norton

Forme geometriche squadrate definiscono con precisione ogni elemento di Norton, a partire dai braccioli e dallo schienale che accolgono con delicatezza le sedute. Estremamente confortevole grazie agli ampi cuscini, Norton conferisce agli ambienti un aspetto contemporaneo ed essenziale.

Square geometric shapes define every element of the Norton sofa, from the armrests to the backrests that lead delicately into the seat cushions. Extremely comfortable thanks to the large cushions, the Norton sofa gives a modern, minimalist feel to any space.





norton
divano 4 posti maxi/
maxi four-seater sofa

agatha
libreria 5 ripiani/
bookcase, 5 shelves
cm 180 x h. 188



La chaise longue estende il piacere della comodità.
The chaise longue extends the comfort even further.
Maxi four-seater sofa.



norton
comp. 7

holly
poltroncina/
armchair

agatha
libreria 3 ripiani/
bookcase, 3 shelves
cm 180 x h. 108



norton
comp. 1

agatha
libreria 3 ripiani/
bookcase, 3 shelves
cm 180 x h. 108

ambra
lampada/
lamp

consolle
tavolino/
table

norton

La pulizia formale di Norton si declina nelle varianti ad angolo e con chaise longue, creando poliedriche soluzioni di arredo e molteplici progetti per ogni spazio.

The Norton sofa's clean lines also extend to the corner model and chaise-end model, creating multi-faceted furnishing solutions and a wealth of designs for every space.



norton
divano 4 posti maxi/
maxi four-seater sofa

Poltrone / Divani Armchairs / Sofas

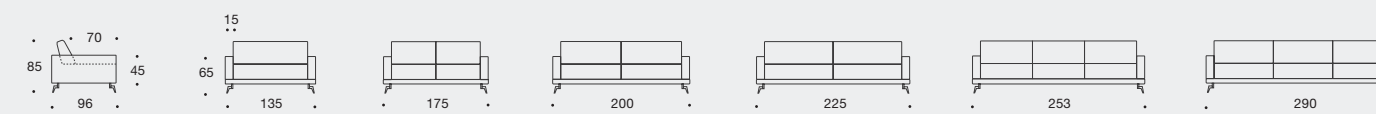

Elementi laterali Lateral elements

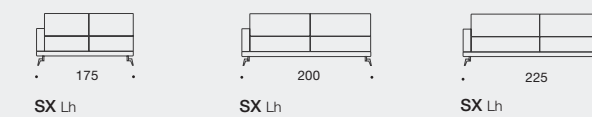

Chaise longue Chaise longue

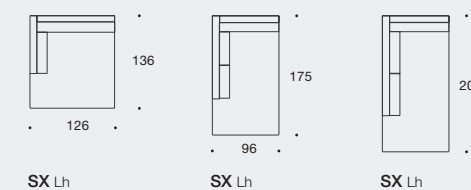

Composizione divani Sofas composition

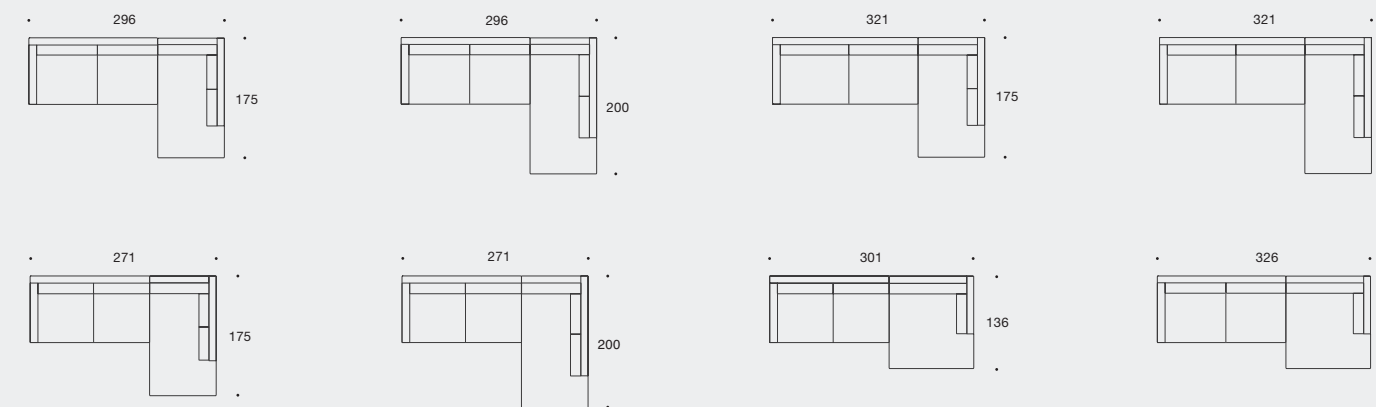



austin

Una geometria essenziale e pura, che con un unico segno disegna la base, i braccioli e lo schienale. Il comfort si fa versatile con gli schienali reclinabili e il relax assume varie forme con il sistema componibile in diverse soluzioni. Con Austin il living è in continua evoluzione: perfetto per chi ama adagiarsi sul divano, non nella vita.

Pure, essential shapes that mark out the base, armrests and backrests in one smooth line. Comfort is versatile with reclinable backrests, and relaxation comes in different shapes and sizes with the modular system. With the Austin sofa, the living room continues to evolve: perfect for those who like to take it easy on the sofa, but not in life!



austin
divano 4 posti maxi/
maxi four-seater sofa

agatha
libreria 5 ripiani/
bookcase, 5 shelves
cm 180 x h. 188

consolle
piano marmo/
marble-top console table
cm 160 x 50



Gli schienali sono reclinabili e regolabili
in due inclinazioni.
The backrests are reclinable and adjustable
in two positions.





austin
comp. 9

consolle
piano marmo/
marble-top console table
cm 80 x 50

credenza
finitura noce/
sideboard in walnut finish
cm 240 x h. 76,5

Una funzionalità contemporanea per esprimere tanti livelli di comfort.
Modern functionality, so many levels of comfort.



austin

Semplice ma deciso, funzionale ma con stile. Austin ha tutte le caratteristiche per valorizzare il living adattandosi alle esigenze estetiche e progettuali più attuali.

Simple, but on target; functional, but with style. The Austin sofa has all the traits to add value to your living space, adapting to aesthetic needs and new design projects.



austin
divano 4 posti maxi/ maxi four-seater sofa

Poltrone / Divani Armchairs / Sofas

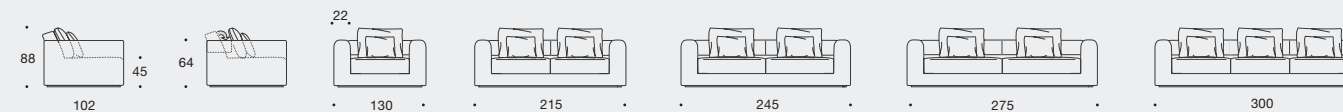

Penisole Peninsulas

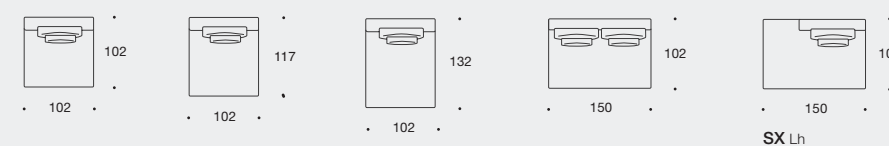

Pouf Poufs

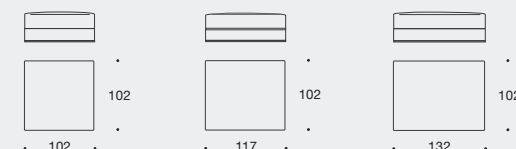

Cuscini Cushions



Composizione divani Sofas composition

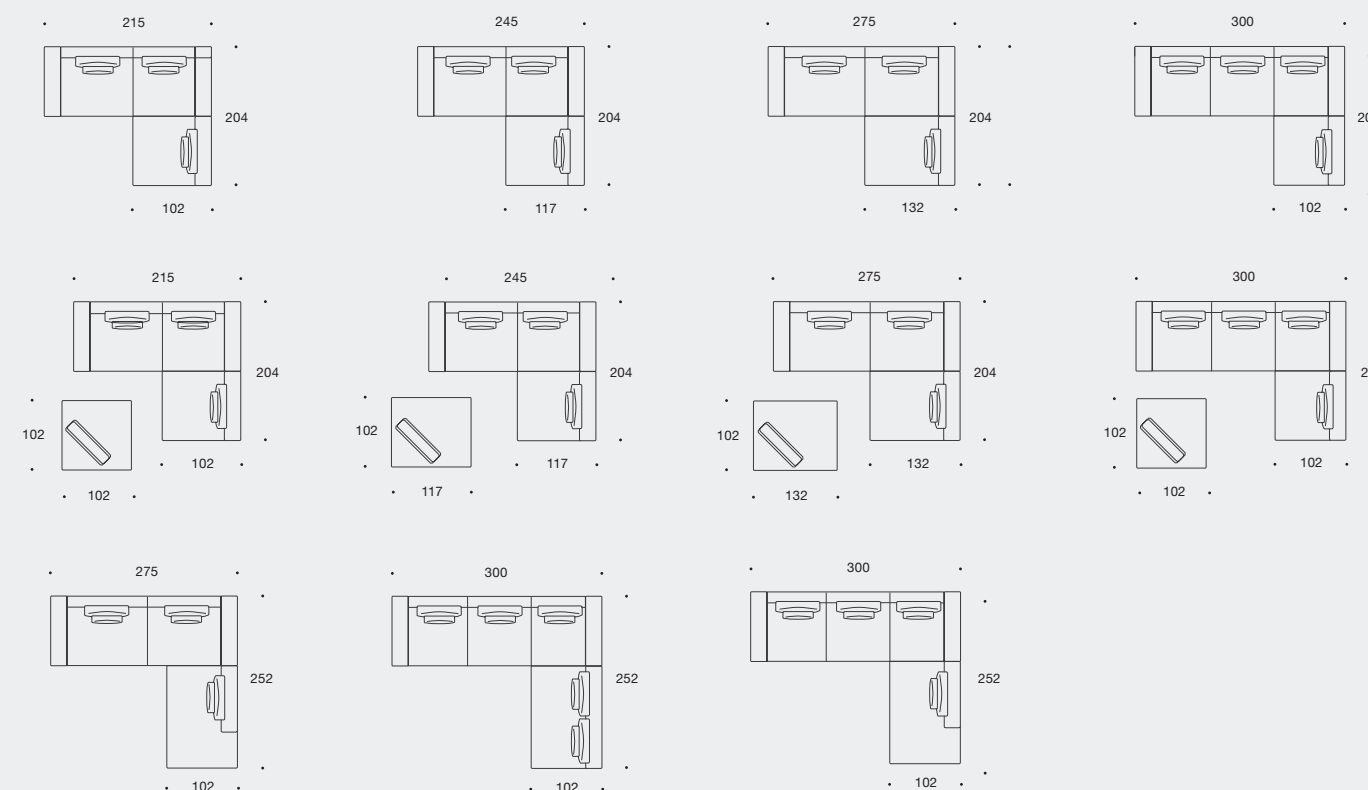

william

Un divano multifunzionale che oltre a offrire un assoluto relax, può integrarsi con una pratica base di appoggio. Un bracciolo con tre alternative di larghezza e un fondo prolungato che diventa tavolino sono i tratti distintivi di William. Il cuscino dello schienale è disponibile con o senza movimenti, ma in ogni caso la comodità è garantita.

A multi-functional sofa which not only offers you total relaxation, but also can be integrated with a practical support base. An armrest that comes in three different widths and an extended base-come-table are the distinguishing features of the William sofa. The backrest cushion is available either fixed or movable, but in either case comfort is guaranteed.





william
comp. 7



Il cuscino si alza e si abbassa a seconda delle esigenze e del relax.
The cushion lifts up and down according to your relaxation needs.





william
comp. 13



william
comp. 4

--- italian comfort

william
comp. 4



057

VALENTINI



Negli spazi più ampi la versione con penisola trova il suo living ideale.
The chaise-end model is at home in larger living room spaces.

william

La scelta del bracciolo racconta diversi modi di interpretare la comodità: larghezza 16 per chi predilige i profili sottili, 26 per andare sul sicuro o 36 per chi ama il design di spessore.

The choice of armrest tells the tale of different ways of interpreting comfort: 16 cm wide for those who prefer slim profiles, 26 cm for a safe choice, or 36 cm for those who love design with depth.



william comp. 1

william relax

Ogni cuscino è dotato di un sistema relax, che permette di scegliere l'inclinazione dello schienale.

Each cushion is fitted with a relaxation mechanism, that allows you to chose the incline of the backrest.



william relax divani/ sofa

Elemento Centrale Central Element

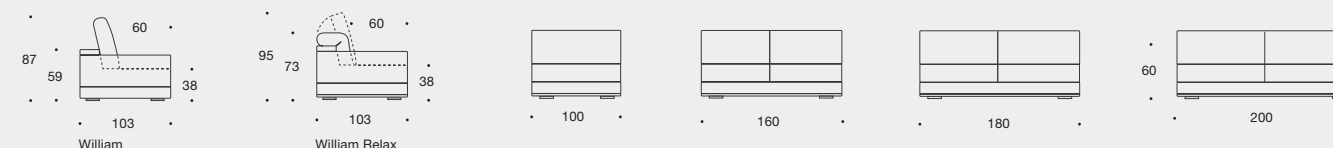

Penisola Peninsula

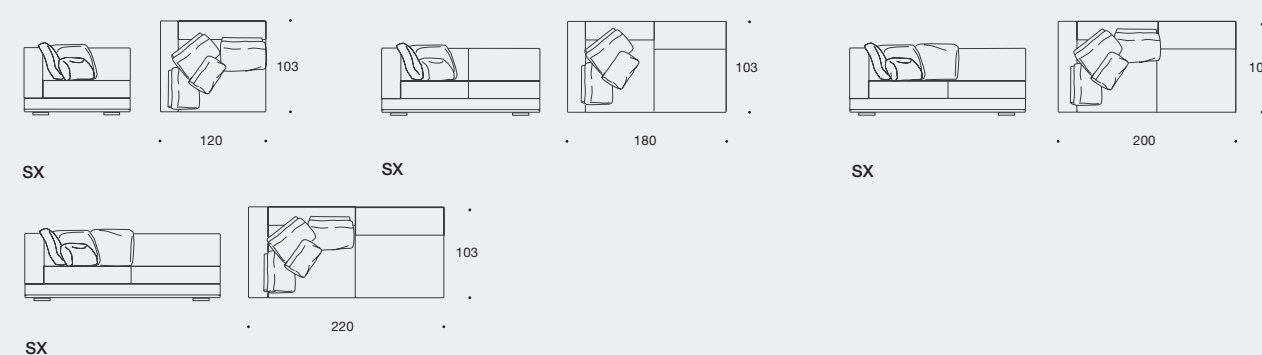

Bracciolo Arm

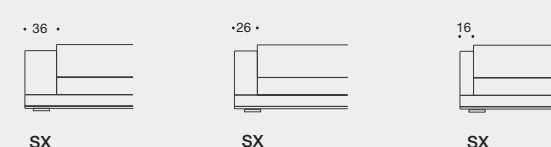

Piano Platform

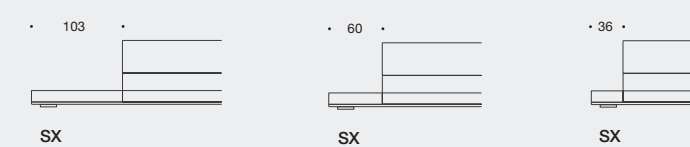

Chaise Longue Chaise longue

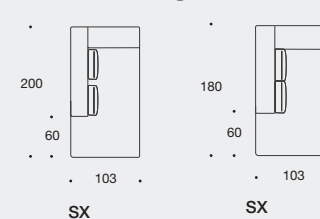

Cuscino Cushion

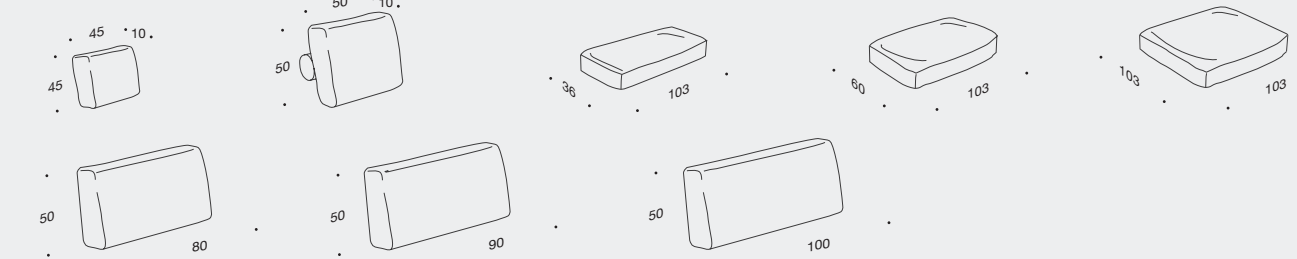

Vassoio Top

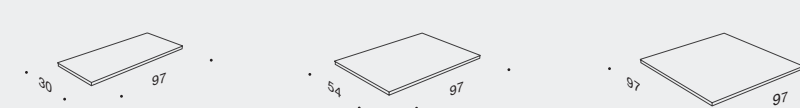



jacob

Estremamente modulare e del tutto personalizzabile, Jacob manifesta la propria flessibilità in ogni suo dettaglio. Elementi più o meno larghi, con o senza schienale, dotati o meno di bracciolo, danno vita a composizioni adattabili a qualsiasi tipo di ambiente. Non solo un divano, dunque, Jacob è molto di più: è comodità a prima vista.

Modular to the max, and fully customisable, the Jacob sofa is flexible in its every detail. Wider and narrower elements, with or without a backrest and armrest, create compositions that can be adapted to any type of space. Much more than a sofa, Jacob is then much more: comfort at first sight.



jacob
divano 4 posti/
four-seater sofa

clive
tavolino piano marmo/
marble-top table
cm 120 x 120

credenza
finitura noce/ sideboard in walnut finish
ante laminato nero opaco/ matt black laminate doors
cm 200 x h. 76,5

Una doppia fila di cuscini
per moltiplicare il relax.
Two rows of cushions for
a relaxation boost.





jacob
comp. 2

agatha
libreria 3 ripiani/
bookcase, 3 shelves
cm 180 x h. 108

jacob

Jacob è componibile a piacere e può essere assemblato in soluzioni compatte e lineari o più generose e ad angolo, sempre con sedute ampie e schienali confortevoli.

The Jacob sofa can be assembled to taste in compact and linear solutions, as well as larger or corner solutions, always with roomy seats and comfortable backrests.



jacob
divano 4 posti/ four-seater sofa

Poltrone / Divani Armchairs/Sofas



Elemento centrale Central Element

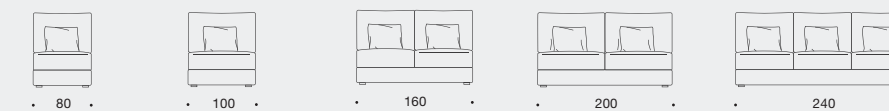

Elementi laterali Lateral elements

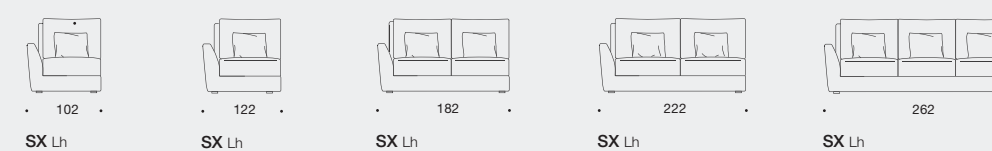

Angolo Corner element

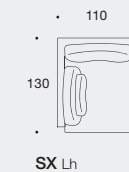

Pouf Poufs



Vassoio Top in

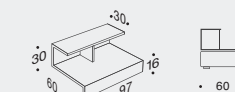

Piano appoggio Platform



Composizione divani Sofas composition

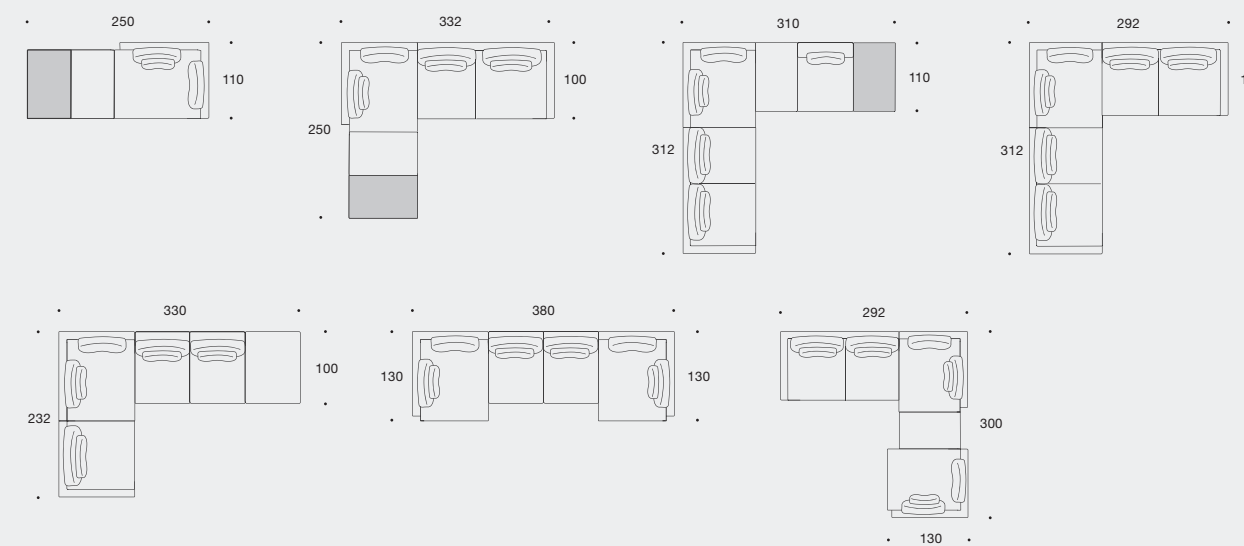

slim

Un profilo sottile disegna il contorno del divano: dallo schienale scende verso la base attraverso il bracciolo per poi continuare il suo percorso senza interruzioni. Nella sua interezza, la struttura accoglie i cuscini e fa da cornice al design. Slim è l'espressione formale di una comodità leggera e moderna.

A subtle profile traces the outline of this sofa: from the backrest down to the base, along the armrest and beyond, in a fluid and unbroken line. As a whole, the frame cradles the cushions and frames the design. The Slim sofa is the formal expression of a light, modern take on comfort.





slim
comp. 2



slim
divano 4 posti maxi +/- maxi four-seater sofa +



slim
divano 4 posti/ four-seater sofa

Cuciture e lavorazioni artigianali sono il punto di forza di ogni dettaglio.
Use of stitching and artisan techniques are the strong point of every detail.



Il total white rende Slim ancora più leggero e molto contemporaneo.
The all-white look lightens the design of the Slim sofa even further, and creates an ultra-modern look.

slim
divano 4 posti/
four-seater sofa



slim

Il design di Slim è snello in qualsiasi versione e composizione, da quelle essenziali a quelle più articolate. Il divano perfetto per vivere in tutta leggerezza.

The Slim sofa's design is streamlined in all models and compositions, from minimalist to those that are more structured. This is the perfect model for a light-and-airy sofa experience.



slim
comp. 4

Poltrone / Divani Armchairs/Sofas

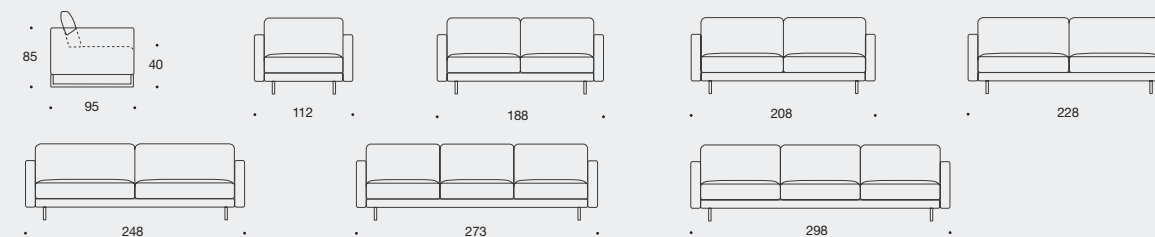

Elementi centrali Central Elements

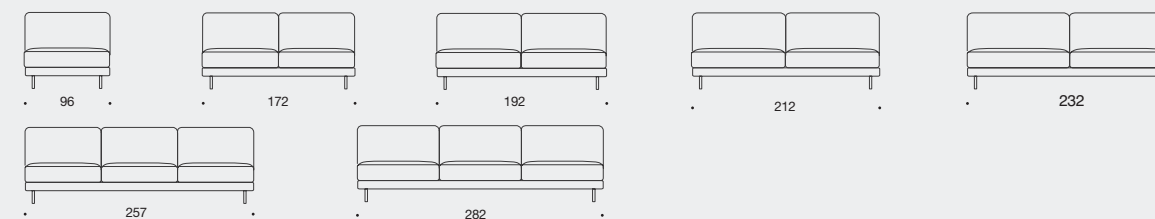

Elementi laterali Sx / Dx Lateral elements Lh / Rh

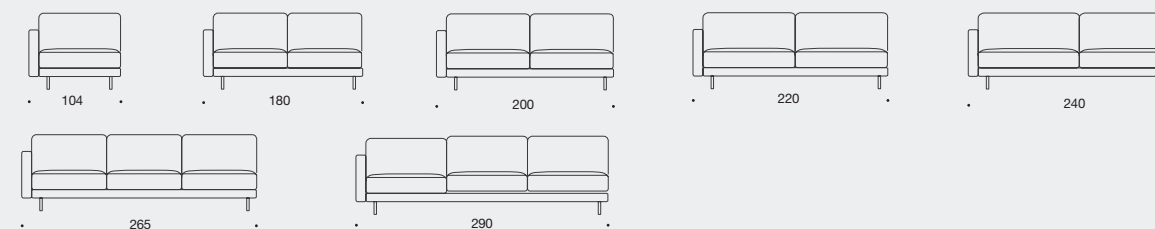

Penisole Peninsulas

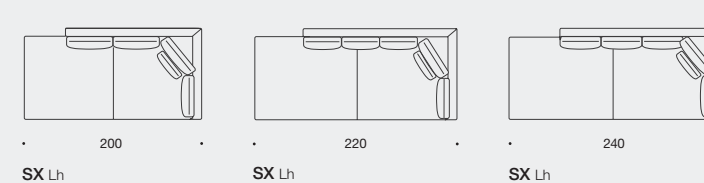

Pouf Poufs

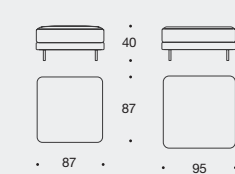

Cuscini Cushions

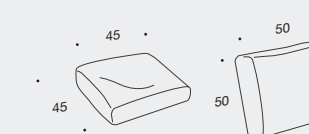

Composizione divani Sofas composition

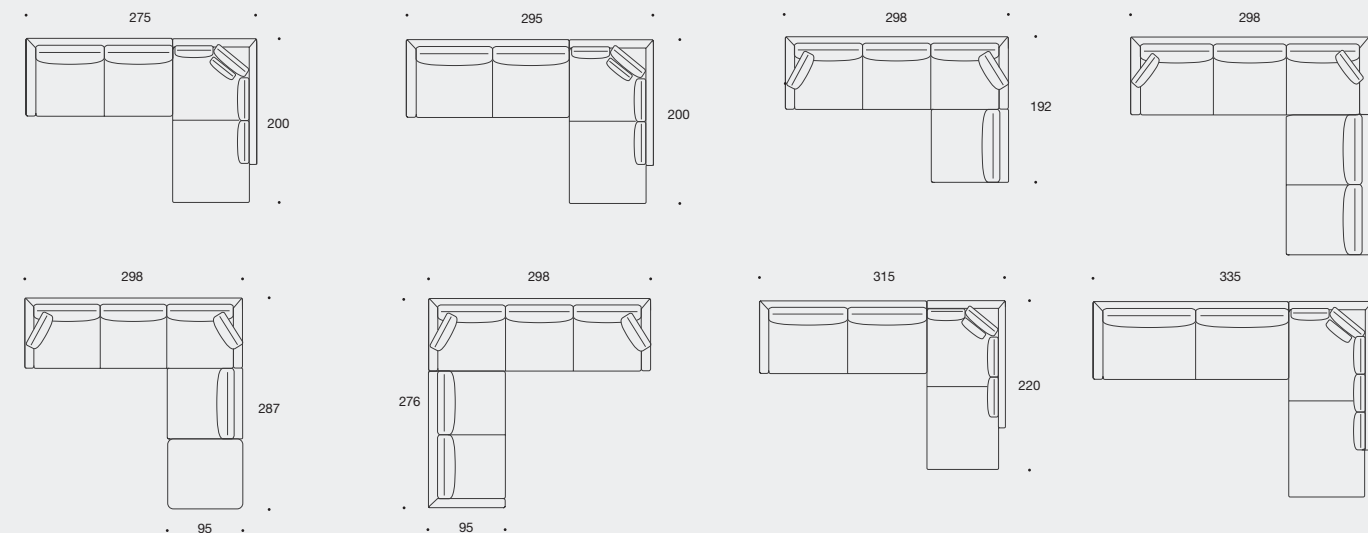

bastian

Il design firmato da Enzo Berti propone un modo di vivere e gestire gli spazi innovativo e poliedrico, che da un lato esalta i valori del salotto tradizionale e dall'altro ne interpreta la funzionalità in chiave contemporanea. Un gioco di schienali e braccioli che si alternano in variante fissa e mobile permette di creare nuove forme e composizioni.

This design by Enzo Berti offers an innovative and multi-faceted way of experiencing and managing spaces which, on the one hand, exalts the values of a traditional living room and, on the other hand, interprets its functionality in a modern key. Backrests and armrests alternate and come in fixed and mobile variants, allowing you to create new shapes and compositions.





bastian
comp. angolo/
corner composition

holly
poltroncina/
armchair

credenza
finitura noce/ walnut finish sideboard
ante radica/ root wood doors
cm 140 x h. 90

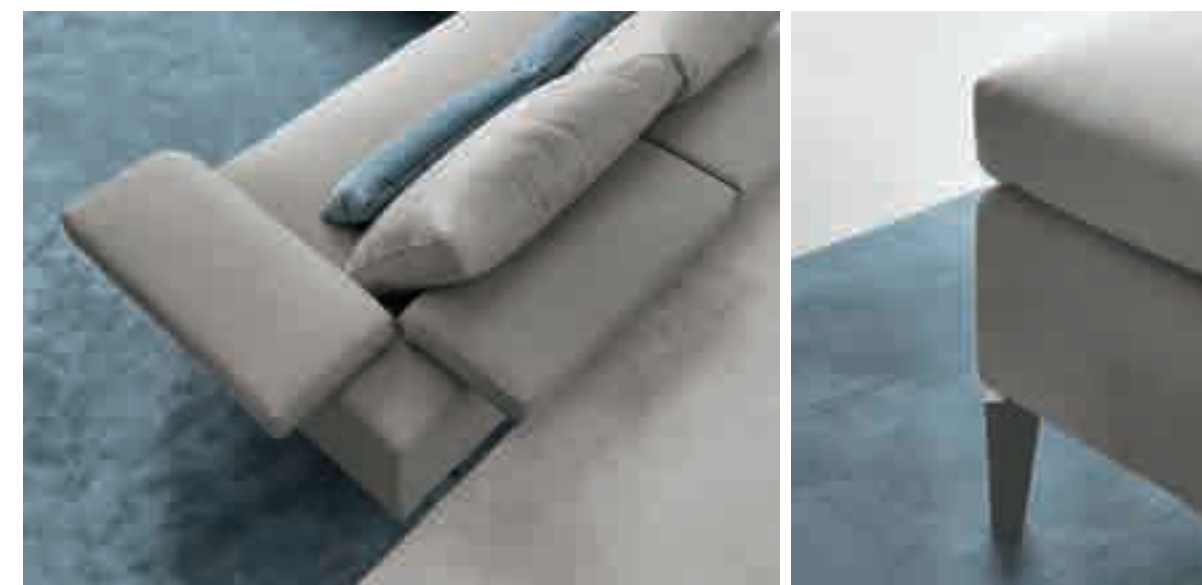

Braccioli e schienali in movimento per un divano mai uguale a sé stesso.
The armrests and backrests can be moved, meaning the sofa is never the same twice.



bastian
comp. angolo/
corner composition

agatha
libreria 3 ripiani
bookcase, 3 shelves
cm 180 x h. 108

consolle
piano marmo/
marble-top console table
cm 80 x 50
cm 160 x 50

Dinamico e creativo: lo stile di Bastian è libero dagli schemi.
Dynamic and creative: the style of the Bastian sofa knows no boundaries.



bastian
comp. 8

agatha
libreria/
bookcase
cm 180 x h. 108

clive
tavolino/table
piano marmo/
marble top
cm ø 120

credenza
finitura noce/ walnut finish sideboard
ante radica/ root wood doors
cm 140 x h. 90



Il bracciolo diventa schienale e
la comodità cambia verso.
The armrest becomes a backrest
and comfort changes face.



bastian

Multiforme e versatile, Bastian è un divano dalla spiccata componibilità. Progettato per adattarsi a tutti gli spazi, Bastian può cambiare forma in continuazione.

Multi-faceted and versatile, Bastian is a modular sofa par excellence. Designed to adapt to every space, the Bastian sofa can change its shape continuously.



bastian
comp. 8

Basi Structures

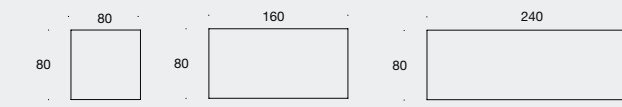

Braccioli Fixed armrests



Pouf Poufs

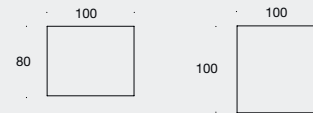

Cuscini Cushions

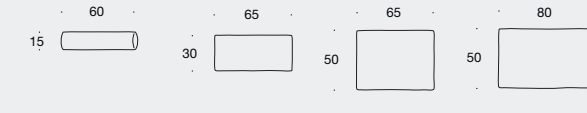

Composizioni divani Sofas composition

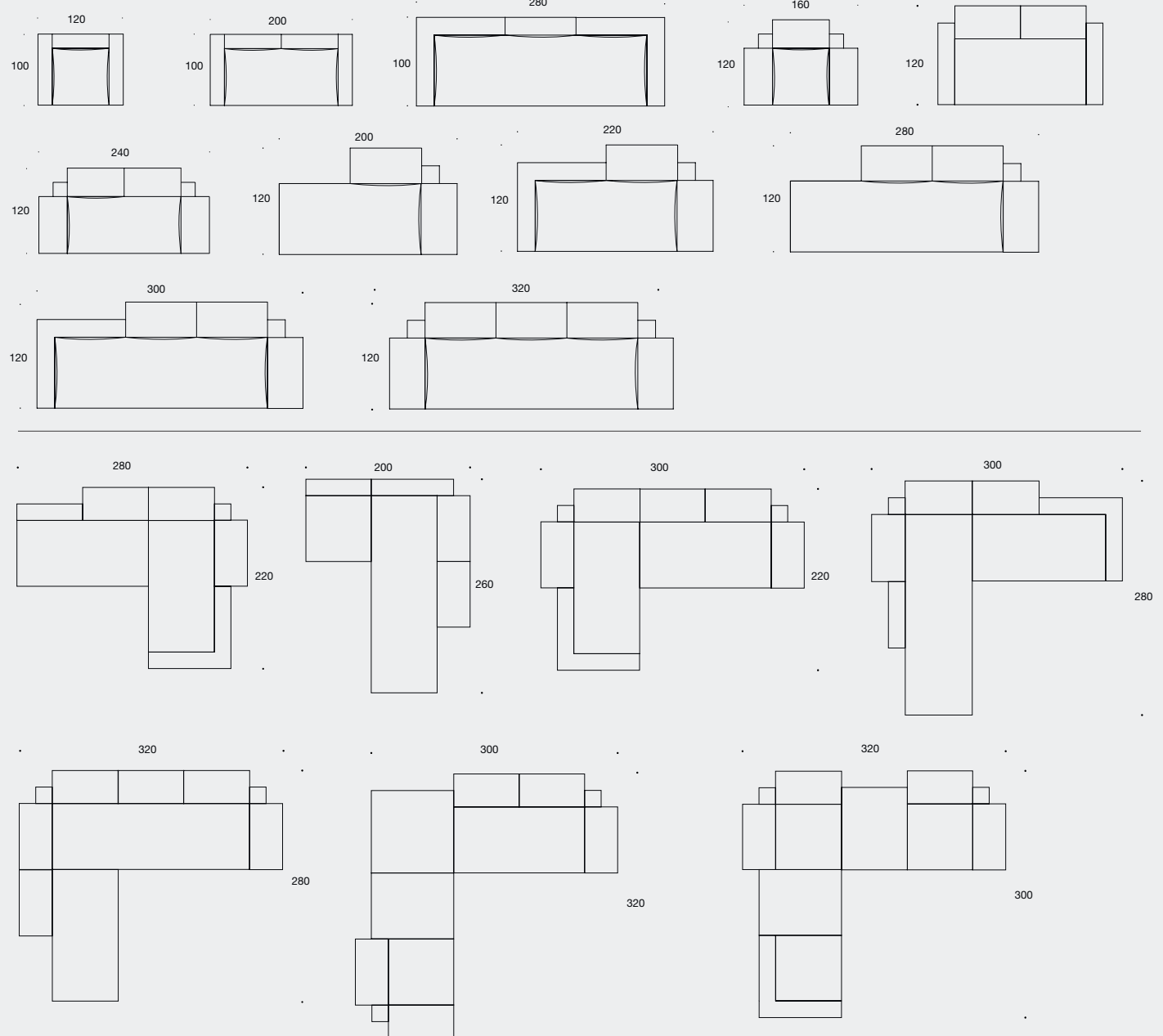

lambert

Un progetto innovativo firmato Enzo Berti che rivoluziona il modo di interpretare la chaise longue, definita per la prima volta con un ampliamento della profondità dello schienale, che arretra conferendo nuovo spazio e comfort alla seduta. Inoltre, Lambert integra elementi d'arredo allo schienale per aggiungere zone d'appoggio all'area relax.

An innovative project by Enzo Berti, which revolutionises the way of interpreting the chaise longue: for the first time a deep backrest moves backwards, giving new comfort and space to the seat. What's more, Lambert also integrates furniture elements into the backrest, to create handy surfaces in the relaxation space.



Geometrie inedite creano un angolo perfetto per la comodità.
Unusual geometrical forms create the perfect corner for comfort.



lambert
comp. 7

holly
poltroncina/
armchair

consolle
piano marmo/
marble-top console table
cm 160 x 50

clive
tavolino/ table
cm ø 120

agatha
libreria 5 ripiani/
bookcase, 5 shelves
cm 180 x 188

Una composizione ampia e dinamica
per spazi in continuo divenire.
A broad, dynamic composition,
for spaces that continue to grow.



lambert
comp. 9

holly
poltroncina/
armchair

leo
tavolino/ table
piano marmo/
marble-top console
cm 50 x 50

clive
tavolino/table
piano marmo/
marble-top console
cm ø 120

agatha
libreria 3 ripiani/
bookcase, 3 shelves
cm 180 x 108



Un gioco di profondità e di linee
esalta il design.
Different depths and lines bring
out the design.





lambert
comp.

consolle
piano marmo/
marble-top console
cm 160 x 50

credenza
finitura noce/
sideboard in walnut finish
cm 240 x 76,5

clive
tavolino/ table
piano marmo/ marble-top console
cm 120 x 120

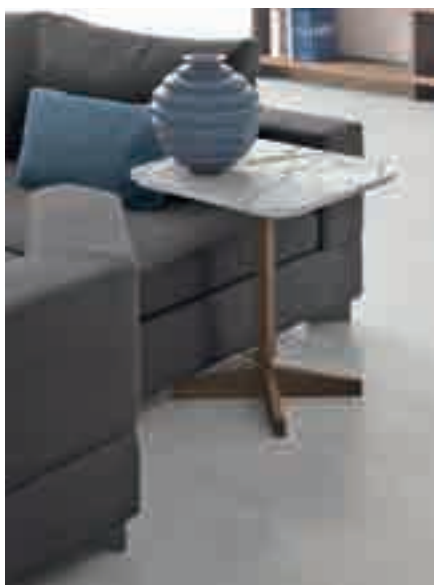

Il tavolino affiancato o integrato al divano aumenta la praticità.
The integrated or accompanying table element is a practical addition.



lambert
comp. 8

consolle
piano marmo/
marble-top console
cm 80 x 50

credenza
finitura noce/
walnut finish sideboard
anta radica/ root wood door
cm 200 x 76,5

leo
tavolino/ table
piano marmo/
marble-top console
cm 50 x 50

agatha
libreria 3 ripiani/
bookcase, 3 shelves
piano marmo/
marble-top console
cm 180 x h. 108



lambert
comp. 1

holly
poltroncina/
armchair

credenza
finitura noce/
sideboard in walnut finish
anta laminato nero opaco/
matt black laminate door
cm 200 x h. 76,5

clive
tavolino/ table
piano marmo/
marble top
cm ø 120

console
piano marmo/
marble top
cm 80 x 50

lambert

Unico nel suo genere, Lambert si discosta dall'idea di divano tradizionale mixando moduli e profondità. La sua particolarità progettuale dà vita a interessanti soluzioni pratiche.

One of a kind, Lambert breaks away from the traditional idea of a sofa, mixing modules and depths. Its unique design gives life to interesting, practical solutions.



lambert
comp. 7

Elementi centrali Central elements

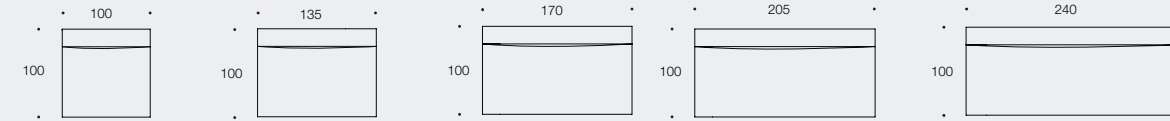

Elementi laterali Lateral elements

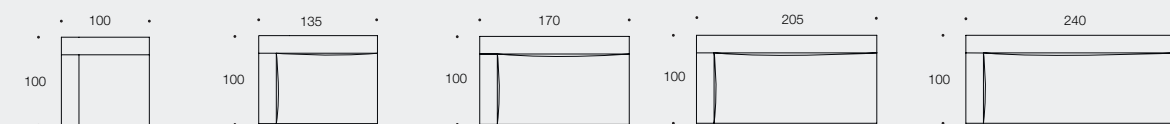

Chaise longue Chaise longue

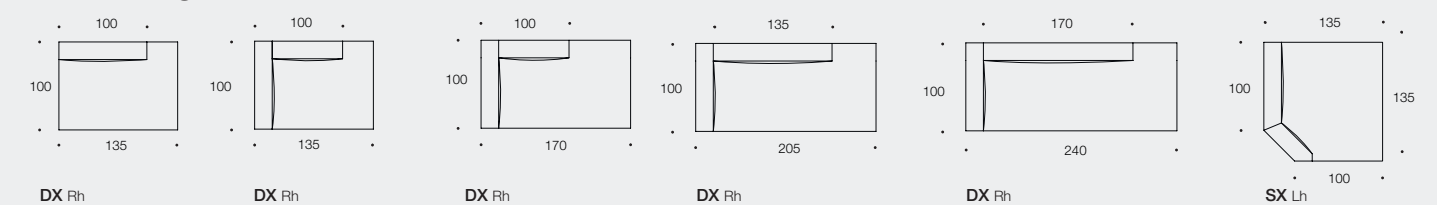

Biangoli Corner elements

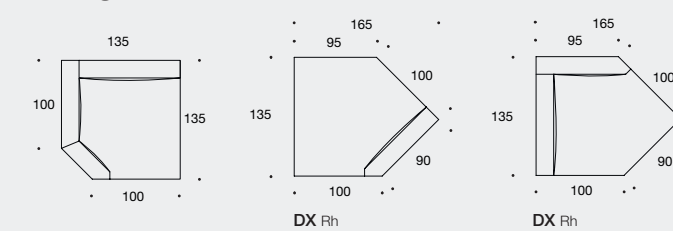

Cuscini Cushions

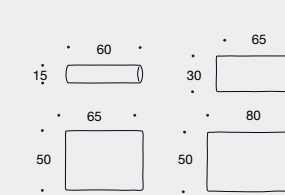

Pouf Poufs

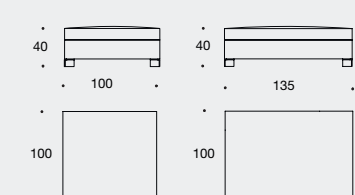

Mensole Shelves

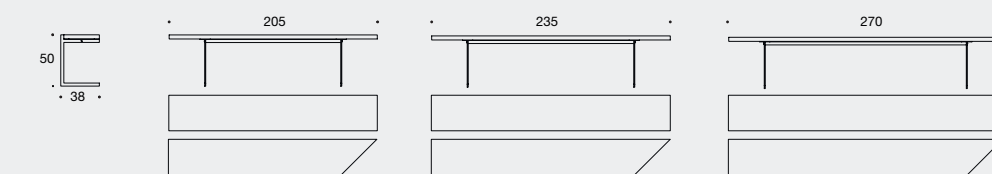

Composizione divani Sofas composition

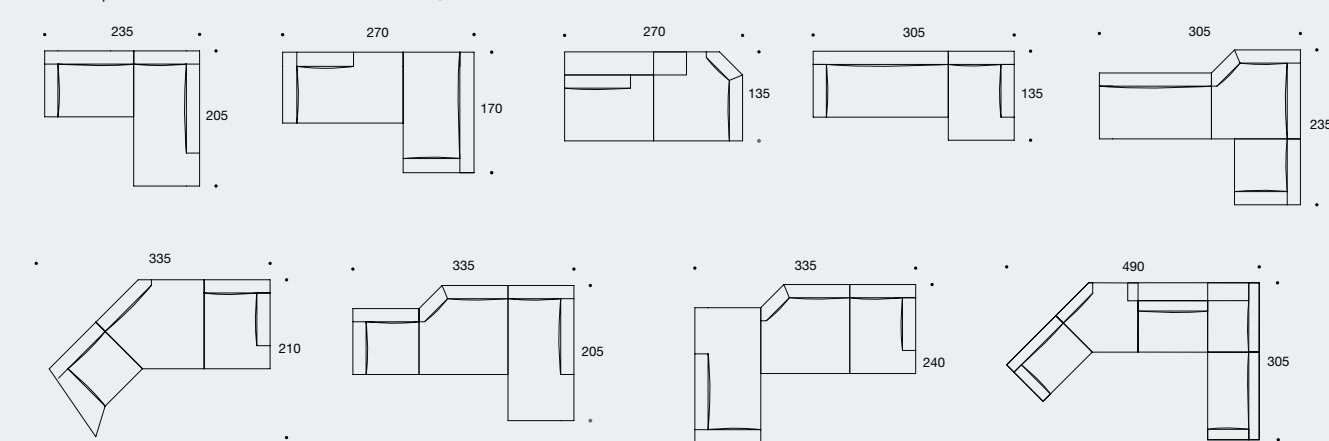



flower

Due elementi “inter-modulari” che possono essere combinati fra loro per dare forma a infinite soluzioni di comodità. Le sedute dalle forme asimmetriche e gli schienali totalmente indipendenti sono posizionabili in piena libertà. Con la sua freschezza e originalità compositiva, Flower fa sbocciare la creatività.

The two inter-modular units can be combined to give form to an infinite number of comfortable solutions. The seats are asymmetrical and the fully independent backrests can be positioned as you like. This fresh and original composition let's creativity bloom.



flower
comp. 2 base
cm 200

elle
poltroncina/
armchair

Elementi uniti oppure uno di fronte all'altro,
Flower offre più soluzioni per lo stesso spazio.
Joined together or facing one another,
the Flower sofa elements create multiple
solutions for the same space.



flower
base
cm 200



Le linee ergonomiche degli schienali conferiscono un comfort esclusivo. La base è realizzata in un tessuto speciale che li rende stabili, totalmente indipendenti e posizionabili su qualsiasi superficie. Per vivere in totale relax.

The ergonomic lines of the backrests add exclusive comfort. The base is made from a special fabric that makes them stable, fully independent and positionable on any surface. Live in total relaxation.



flower
comp. 2



flower

Le infinite combinazioni di Flower lo rendono unico e indispensabile per chi vuole sentirsi libero di cambiare il proprio ambiente senza dover cambiare arredamento.

The infinite combinations offered by Flower make it a unique must-have for anyone who wants to be free to change their living space, without having to change the furniture.



flower comp. 2

Base Ottoman

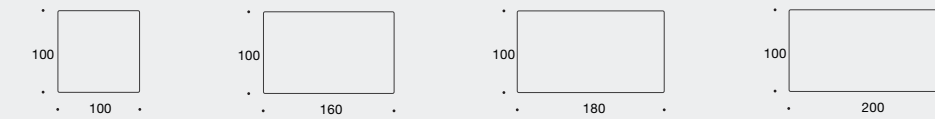

Isole Isles

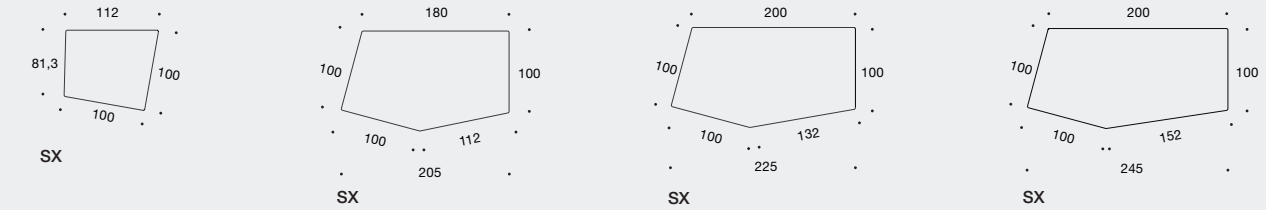

Cuscino Cushion

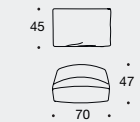

Bracciolo Arm cushion



Composizione divani Sofa composition

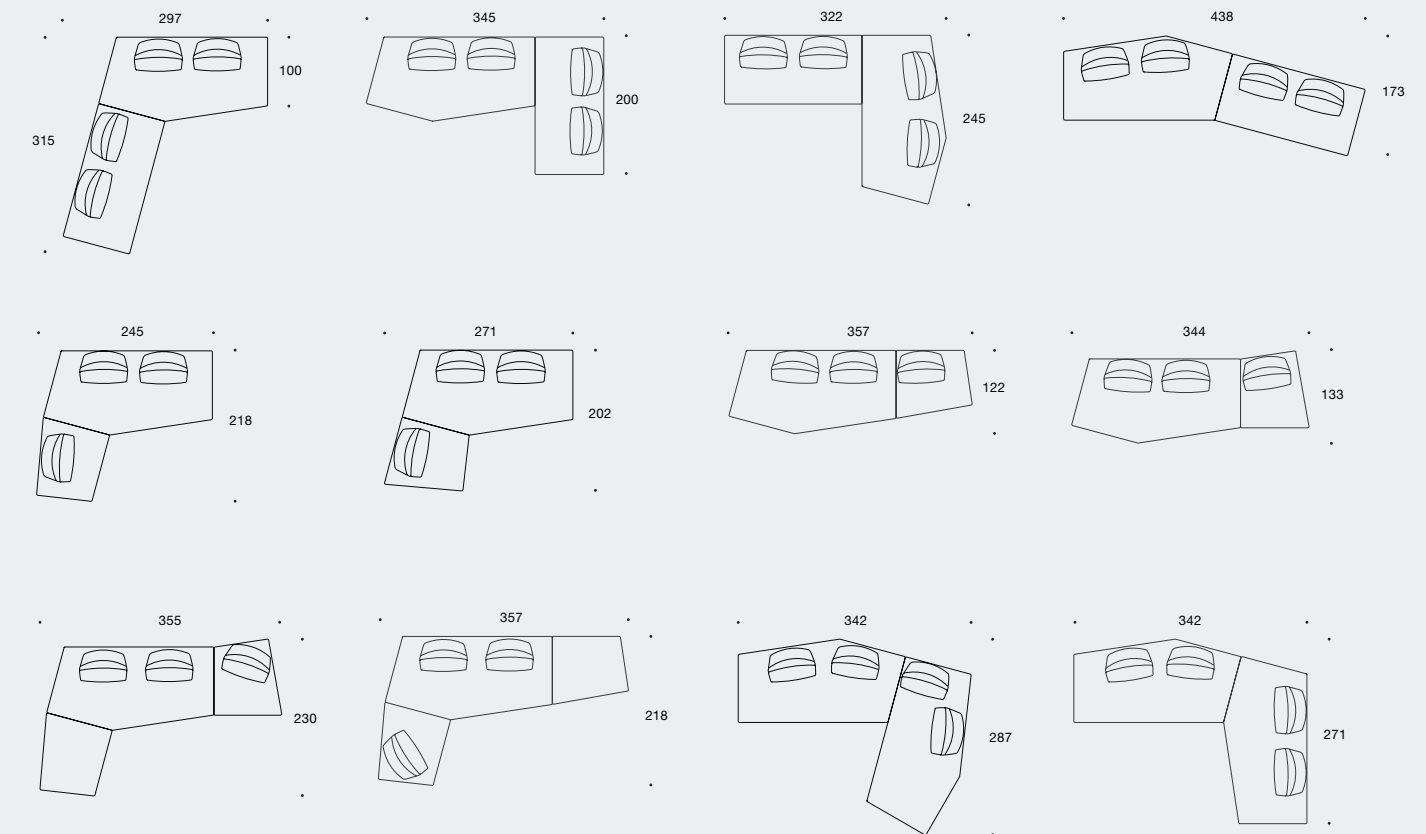



ernest

Un divano dalla linea rassicurante e moderna, ideale per tutti gli ambienti che ricercano negli arredi un'originalità discreta. Una bordatura a contrasto o tono su tono disegna con delicatezza i profili di Ernest, fa da trait d'union tra il bracciolo e lo schienale e mette in evidenza la cura sartoriale di ogni realizzazione.

This sofa has a familiar, modern form, ideal for furnishing any space that seeks discrete originality in the furniture. The contrasting piping or tone-on-tone design lightly traces the profile of the Ernest sofa and joins the armrest and backrest, highlighting the sartorial nature of every feature.



ernest
comp. 2



ernest
comp. 2

ernest

L'imbottitura dei cuscini in poliuretano espanso indeformabile a quote differenziate o in piuma d'oca divisa a scomparti, fa di Ernest un microcosmo dedicato al relax.

The cushion padding in different density expanded polyurethane that holds its shape, or in goose down divided into compartments, makes the Ernest sofa a microcosm of relaxation.



ernest
divano/ sofa
cm 249

Poltrone / Divani Armchairs/Sofas

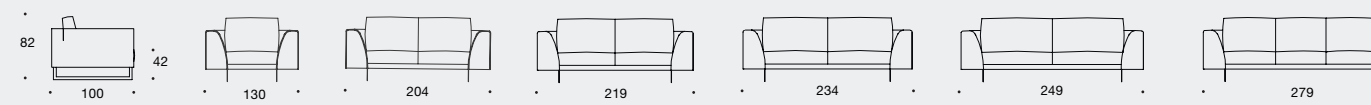

Elementi laterali Lateral elements

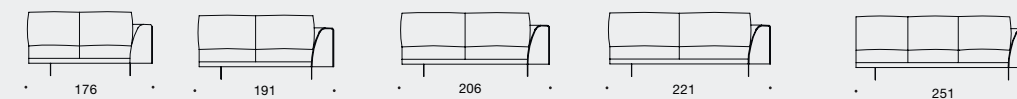

DX Rh

DX Rh

DX Rh

Elemento centrale Central Element

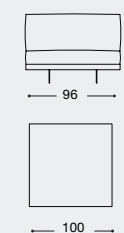

Angolo Corner

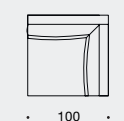

Chaise longue Chaise longue

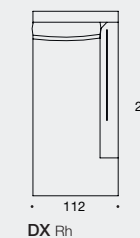
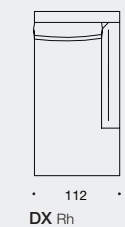
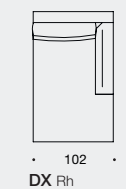

Pouf Pouf

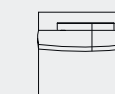

Composizione divani Sofas composition

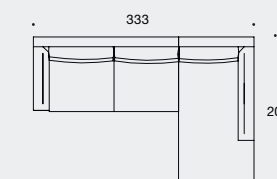
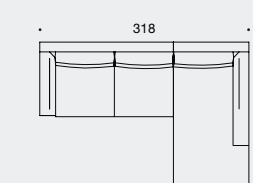
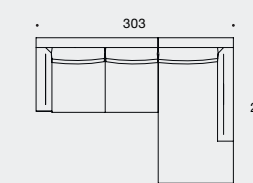
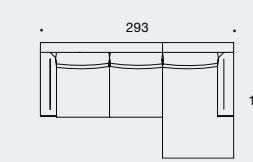
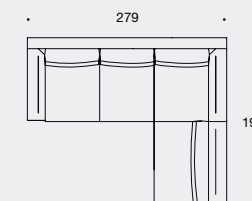

hugo

Le forme eleganti di Hugo adagate sui piedini evocano le sedute d'altri tempi. Braccioli e schienale sono una cosa sola e racchiudono al loro interno i soffici cuscini. Un divano dal taglio sartoriale, che permette di personalizzare la lavorazione dei braccioli per dare unicità ad ogni pezzo e ad ogni ambiente.

The elegant shapes of the Hugo sofa sitting on feet recall the sofas of times gone by. The armrests and backrests are one, and enclose the soft seat cushions. This sofa has a sartorial feel, and the armrests can be personalised to make each element and space unique.





hugo
comp. 3

Con la chaise longue Hugo punta
a un look sofisticato.
With the chaise end, the Hugo sofa
also creates a sophisticated look.





A richiesta su tutti gli elementi, il bracciolo matelassé è un elemento di stile.
On request, the quilted armrest adds an extra element of style.

hugo

Hugo entra in scena con la ricercatezza del suo design, ma anche con una grande varietà di elementi che combinati o abbinati valorizzano l'ambiente.

The Hugo sofa presents a refined design and a wide variety of elements that can be mixed and matched to add value to the space.



hugo
comp. 3

Poltrone / Divani Armchairs / Sofas

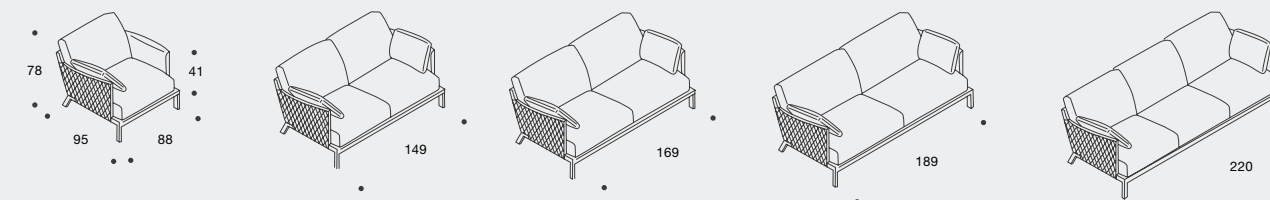

Elementi laterali Lateral elements

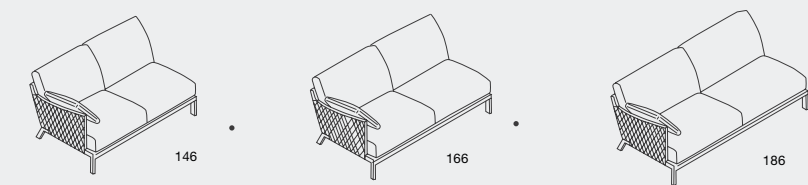

SX / DX Lh / Rh

SX / DX Lh / Rh

SX / DX Lh / Rh

Chaise longue Chaise longue Dormeuse Dormeuse

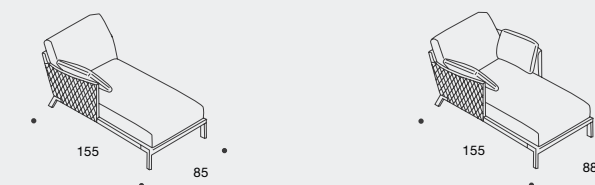

SX / DX Lh / Rh

Pouf Poufs

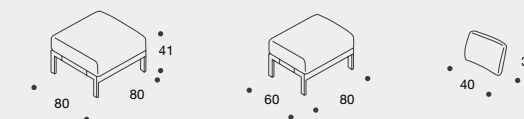

Composizione divani Sofas composition

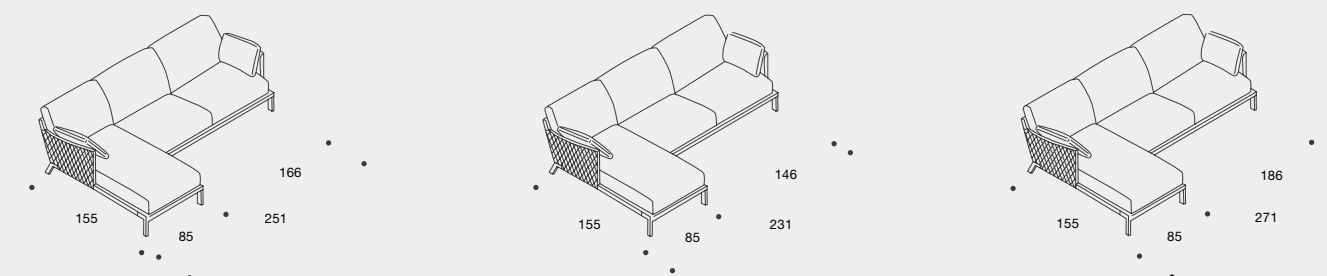



box

Compatto e dalle forme generose, Box ha sedute monoscocca che con un semplice movimento possono allungarsi fino a diventare chaise longue. Una geometria morbida e accogliente, che rende ogni composizione protagonista dello spazio e del relax. Box è il divano perfetto per interni dalla forte personalità.

Compact with bold shapes, the Box sofa has single-unit seats which can be pulled out into a chaise longue in one simple movement. The soft and welcoming shape of this sofa makes the composition the star of the space, and the heart of relaxation. The Box sofa is perfect for interiors with a strong personality.



box
comp. 3



La seduta estraibile trasforma
il design in comodità.
The pull-out seat turns design
to comfort.



box
comp. 3

isa
poltroncina/
armchair



box
divano 3 posti/
three-seater sofa

isa
poltroncina/
armchair

box

La presenza plastica di Box è la sua caratteristica principale e grazie alle molteplici soluzioni compositive può essere inserito in grandi e piccoli spazi.

The shape of the Box sofa is its main feature and, thanks to the many composition solutions, it can be slotted into spaces both large and small.



box
comp. 1

Poltrone / Divani Armchairs / Sofas

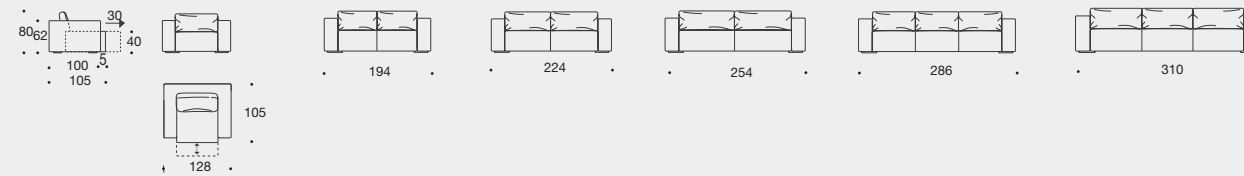

Seduta normale Standard seat

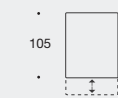

Penisole schienali interi Peninsulas with long backrests

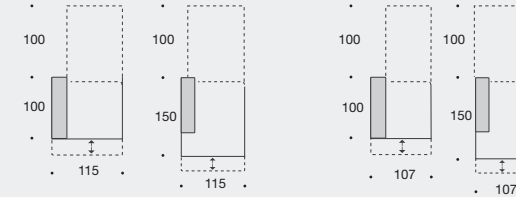

SX / DX Lh / Rh

SX / DX Lh / Rh

Chaise longue Chaise longue

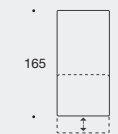

Cuscini Cushions



Composizione divani Sofas composition

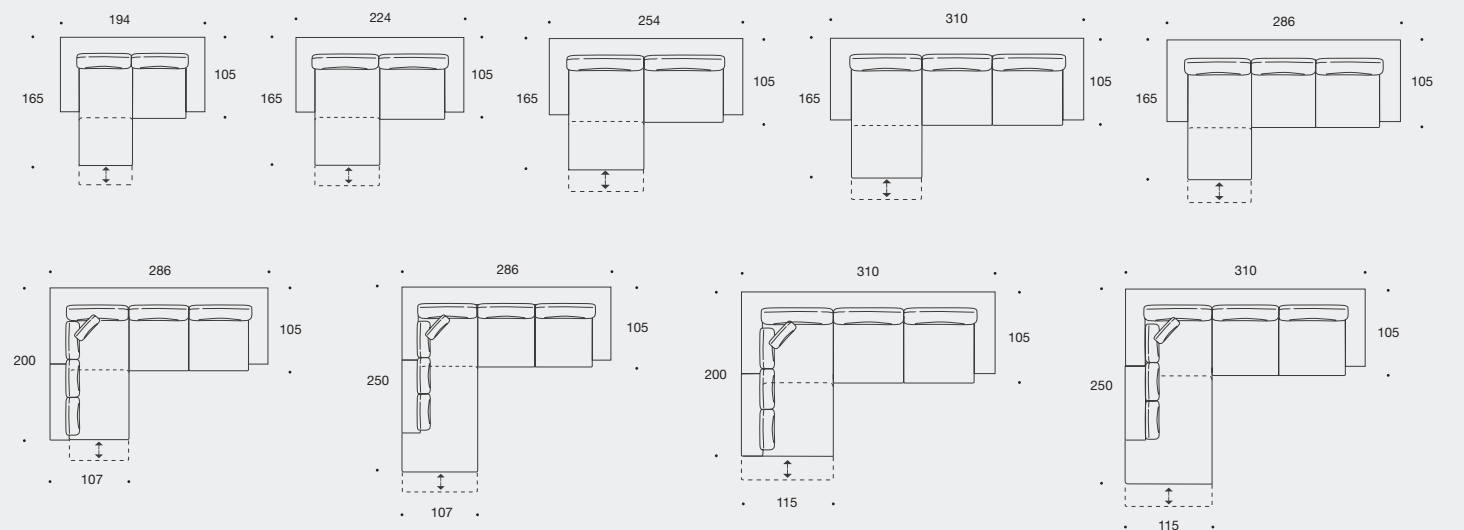



kilt

Elegante nelle forme, sottile nei volumi e prezioso nella cura dei dettagli, Kilt veste il living con classe. I piedini elevano il design nella dimensione della leggerezza e alzano il livello della comodità. Una sintesi di stile per zone giorno ed ambienti moderni, dove Kilt conquista il suo spazio, ma soprattutto crea spazio per il relax.

Elegant in shape, contained in volume, and trim in appearance, the Kilt sofa adorns the living space with class. The feet lift up the design and make it as light as air, as well as raising the level of comfort. A synthesis of style for a modern space or living room, where the Kilt sofa dominates, but leaves plenty of room for relax.



kitt
comp. 6



Un'idea di relax completo
nella versione con penisola.
Total relax for the model
with a chaise end.





kitt
divano 3 posti/
three-seater sofa

lea
poltroncina/
armchair

kilt

Il divano Kilt, con le sue sedute confortevoli e componibili, materializza il concetto di comodità in progetti d'arredo che uniscono stile e funzionalità.

The Kilt sofa with its comfortable, modular seats turns the concept of comfort into furnishing projects that bring together style and functionality.



kilt
comp. 3

Poltrone / Divani Armchairs / Sofas

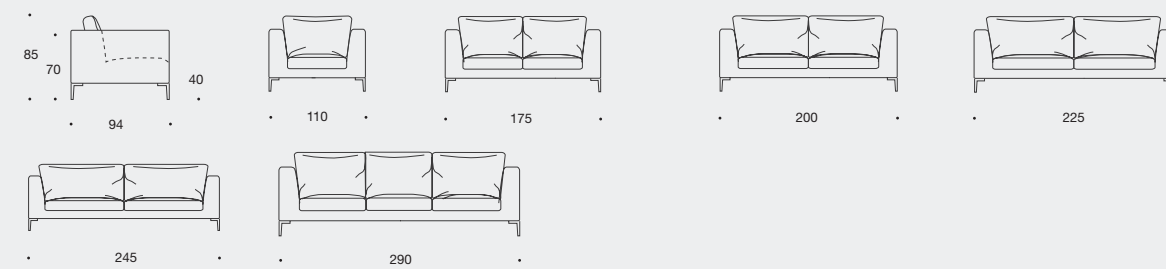

Elementi laterali Lateral elements

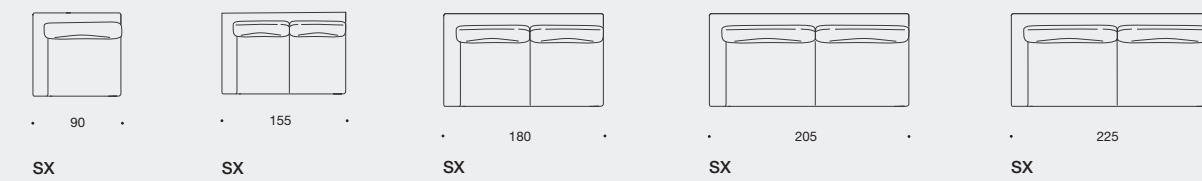

Penisole Peninsulas

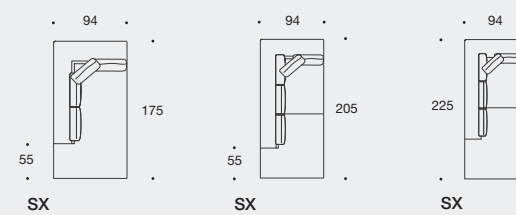

Chaise longue Chaise Longue

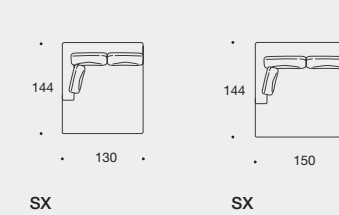

Pouf Poufs

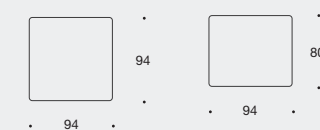

Cuscini Cushions



Composizione divani Sofas composition

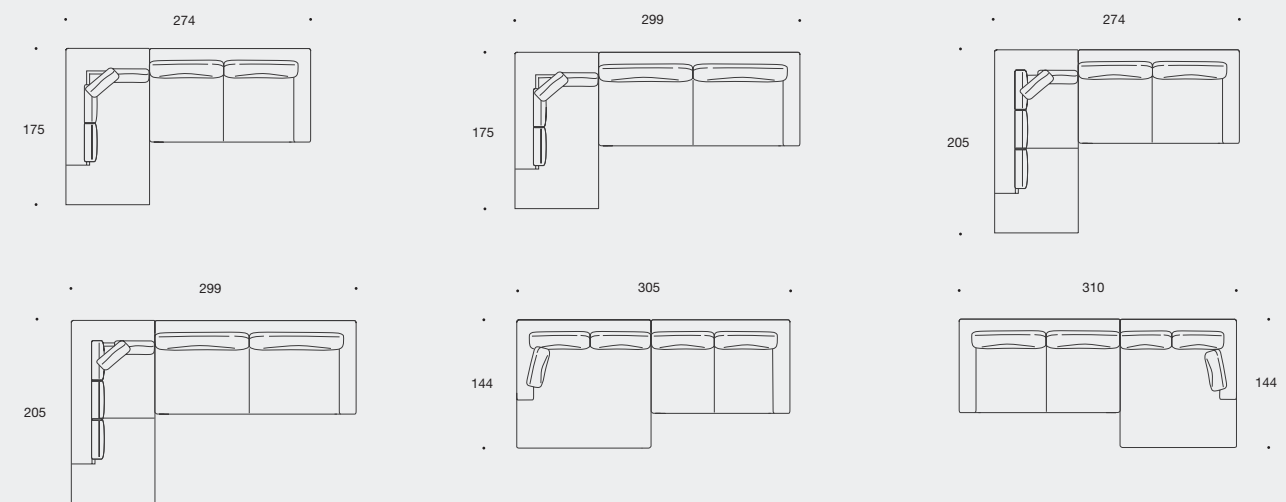

charles

Uno schienale alto e sottile su cui si adagiano maxi cuscini che trasmettono una piacevole sensazione di relax e accoglienza. Le sedute poggiano sulla base a terra conferendo a Charles una personalità solida e comoda, allo stesso tempo. Un look sobrio e contemporaneo, che non conosce il passare del tempo ed è sempre attuale.

The high, slim backrest props up the maxi cushions that convey a pleasant, inviting sense of relaxation.

The seat cushions sit on a low base, giving the Charles sofa sturdy but comfortable personality. A sober yet modern look, that is immune to the passing of time, and always up to date.





charles
comp. 2

Una bordatura a contrasto o tono su tono disegna con delicatezza i profili di Charles.
Contrasting or tone-on-tone piping delicately marks out the profile of the Charles sofa.





charles

Charles dà la possibilità di introdurre nel living nuove geometrie, attraverso un'isola che può essere affiancata alle sedute lineari. Il design cambia, la comodità resta.

The Charles sofa brings new shapes into the living room, with a chaise end which can be paired with linear seats. The design changes; the comfort level stays.



charles
divano 3 posti/ three-seater sofa

Poltrone / Divani Armchairs / Sofas

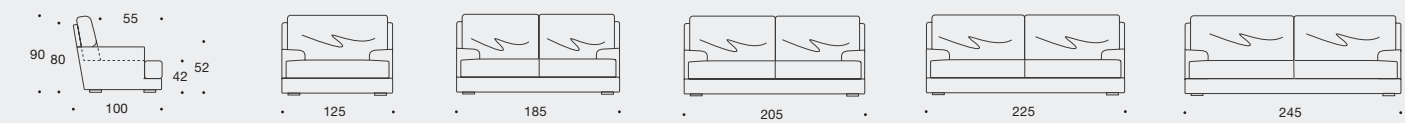

Elementi laterali Lateral elements

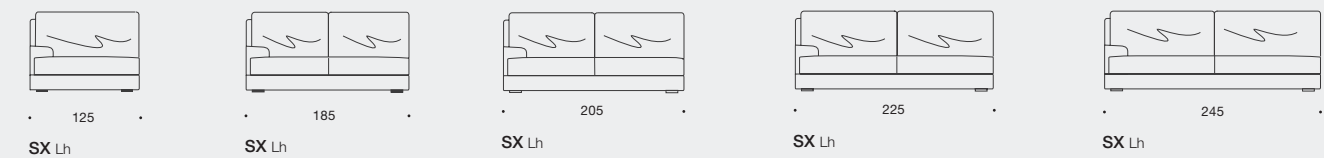

Penisole Peninsulas

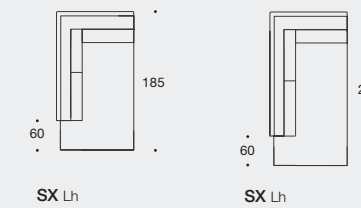

Isola Isle

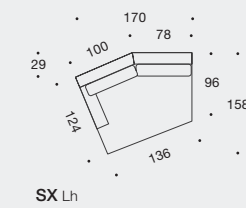

Angolo Corner

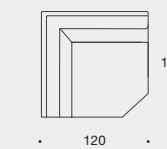

Cuscino Cushion

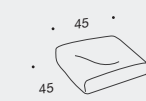

Composizione divani Sofa composition

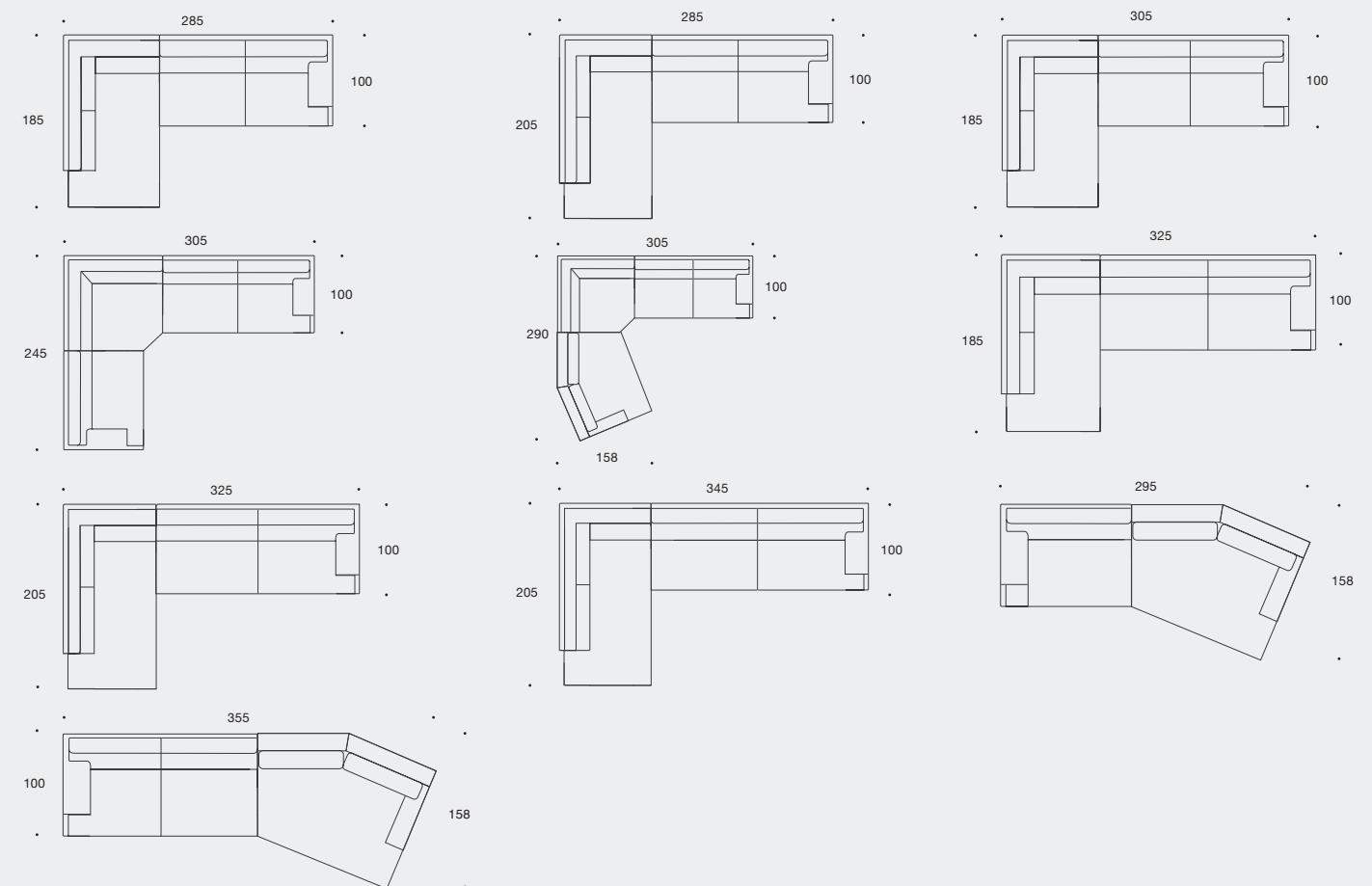

samuel

Un divano di carattere, che si distingue per il design e la tipologia di movimento. Il bracciolo basso e svasato ha una forma originale e allo stesso tempo ergonomica, mentre il meccanismo traslante dello schienale offre la possibilità di regolare le sedute con due diverse profondità. Samuel prende la vita comodamente.

This sofa has character, standing out for its design and mechanisms. The low, sloping armrest has an original shape that is also ergonomic, while the sliding backrest mechanism allows you to adjust the seats to two different depths. The Samuel sofa takes life in its stride.





samuel
comp. 1

Lo schienale si muove avanti o indietro
e la seduta cambia profondità.
The backrests move forwards and backwards,
changing the depth of the seat.



Con la penisola, Samuel diventa ancora più comodo e profondo.
With the chaise end, the Samuel sofa is even deeper and more comfortable.



samuel
comp. 1

samuel

In tutte le varianti e le composizioni, Samuel consente un uso diversificato della seduta. Ideale per chi vuole assecondare in ogni momento la variabilità del relax.

In all of the models and compositions, the Samuel sofa allows you to use the seat in different ways. Ideal for those who want to indulge the varying nature of relaxation at all times.



samuel
divano 3 posti/ three-seater sofa

Divani Sofas



Elementi centrale Central elements

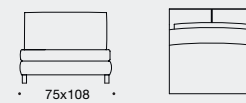

Elementi laterali Lateral elements

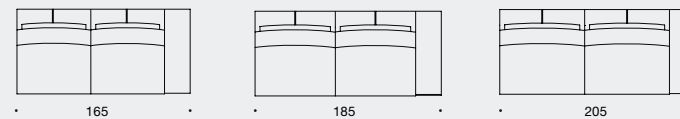

DX Rh

DX Rh

DX Rh

Chaise longue Chaise Longue

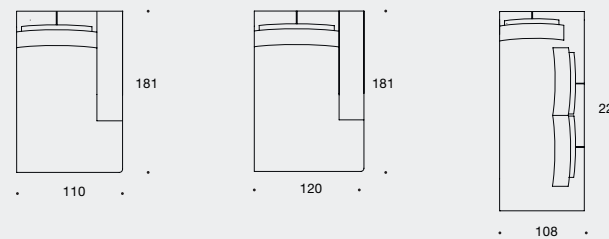

DX Rh

DX Rh

DX Rh

Pouf Poufs

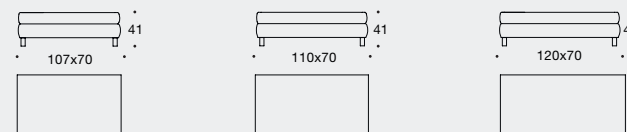

Composizione divani Sofa composition

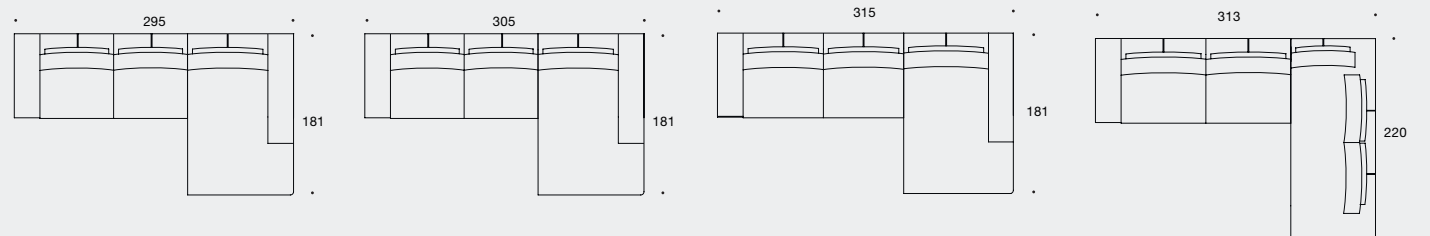



harry soft

La morbidezza si esprime nella forma e nella sostanza di Harry Soft. Con il suo bracciolo ampio, lo schienale comodo e le sedute soffici, il divano Harry Soft si inserisce in living dove il comfort è al primo posto. Le linee bombate e voluminose invitano al relax e infondono serenità, sia a chi le guarda sia a chi le vive.

The soft side of Harry is revealed in the shape and substance of the Harry Soft sofa. With wide armrests, comfortable backrests and soft seats, the Harry Soft sofa fits perfectly into living spaces that prioritise comfort. The curved, bombé lines inspire relaxation and instil a feeling of peace, both for those who see them and those who experience them.



harry soft
divano 4 posti/
four-seater sofa

demetra
poltroncina/
armchair



Schienale e bracciolo caratterizzati da un profilo di forte spessore.
The backrest and armrests have a particularly chunky profile.



harry soft
divano 3 posti/ three-seater sofa

harry soft
comp. 4



La penisola con schienale corto offre tanti modi per stare comodi.
The chaise end with short backrest offers plenty of ways to sit comfortably.



harry soft

Nelle versioni standard a 2, 3 o 4 posti, ma anche nelle composizioni più spaziose e articolate, Harry Soft mantiene il suo aspetto avvolgente e coinvolgente.

In the standard two-, three- or four-seater seater models, as well as in the more structured and roomy compositions, the Harry Soft sofa maintains its inviting appeal.



harry soft
comp. 3

Poltrone / Divani Armchairs / Sofas

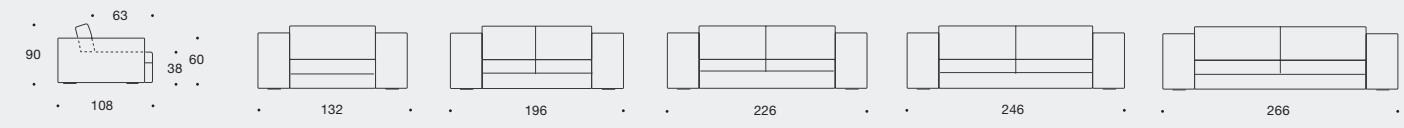

Elementi laterali Lateral elements

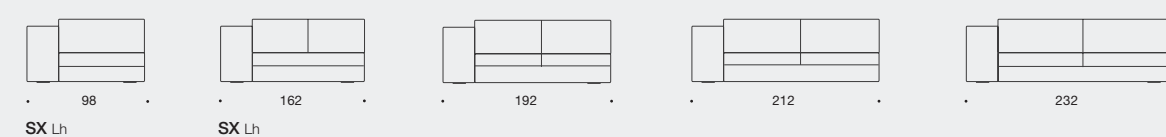

Penisole Peninsulas

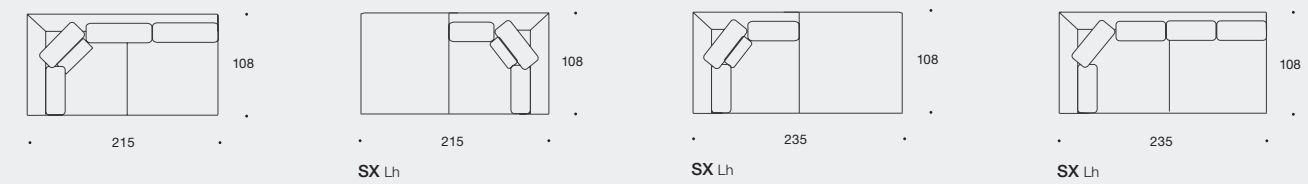

Angolo Corner

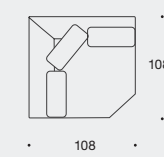

SX Lh

Chaise longue Chaise longue

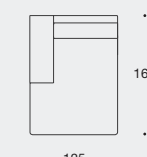

SX Lh

Pouf Poufs

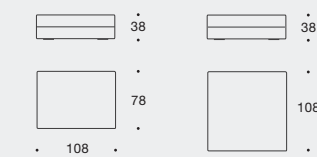

Composizione divani Sofas composition

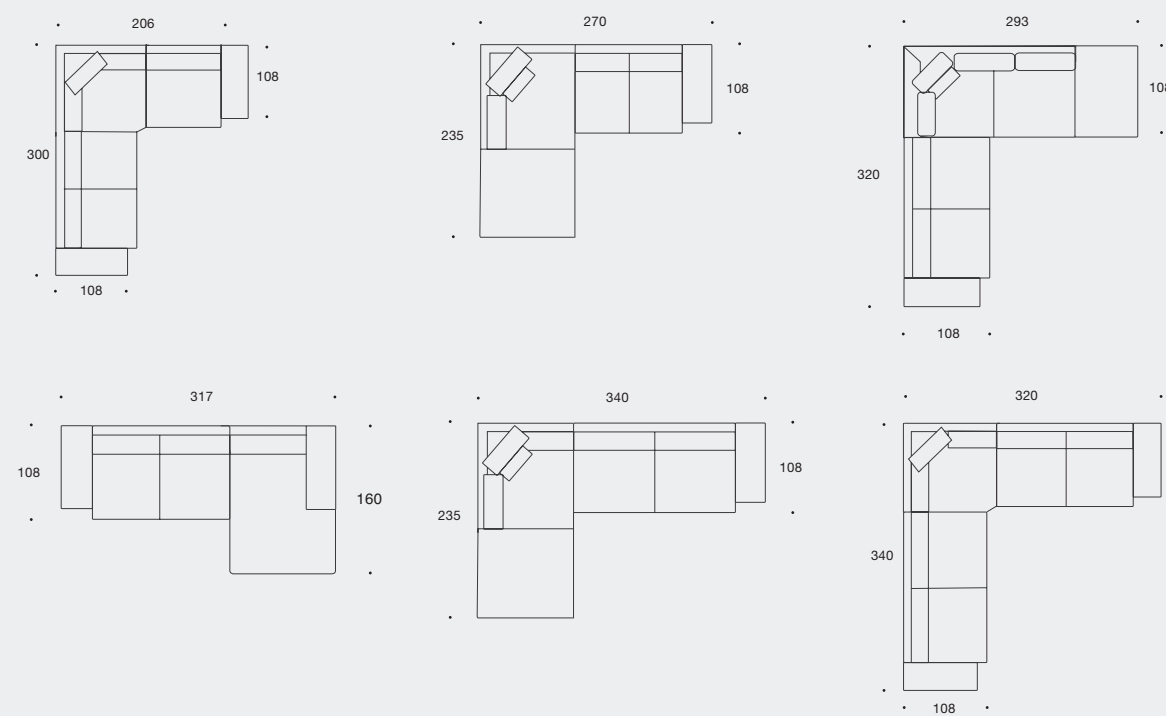



gas

Lineare e semplice, ma solo all'apparenza. Dietro i cuscini, Gas nasconde un meccanismo schienale reclinabile e regolabile a due altezze. Il corpo trova la sua posizione ideale da seduto o sdraiato e può concedersi un relax personalizzato in ogni momento della giornata.

Linear and simple, on the outside. Behind the cushions, the Gas sofa hides a reclinable backrest that can be adjusted to two heights. Whether sitting or laying down, your body relaxes into the ideal position, for a personalised experience at any point in the day.



gas
comp. 4
poltroncina/
armchair



gas
comp. 2
poltroncina/
armchair



Lo schienale si alza o si abbassa
con un semplice movimento.
The backrest lifts up or down with
a simple manoeuvre.



gas
divano 3 posti/
three-seater sofa

gas

L'estrema funzionalità e componibilità di Gas lo rendono ideale per ambienti di tutte le dimensioni. Gas è il divano che si adatta ai ritmi della vita e della comodità.

The modular, functional nature of the Gas sofa makes it ideal for spaces of any size. The Gas sofa adapts to the rhythm of your life and idea of comfort.



gas
divano 3 posti/ three-seater sofa

Poltroncina Armchair



Poltrone / Divani Armchairs / Sofas



Penisole Peninsulas

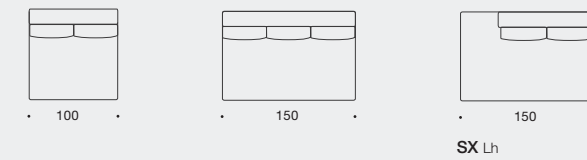

Pouf Pouf

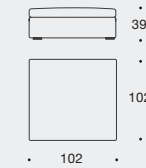

Cuscini Cushions



Composizione divani Sofa composition

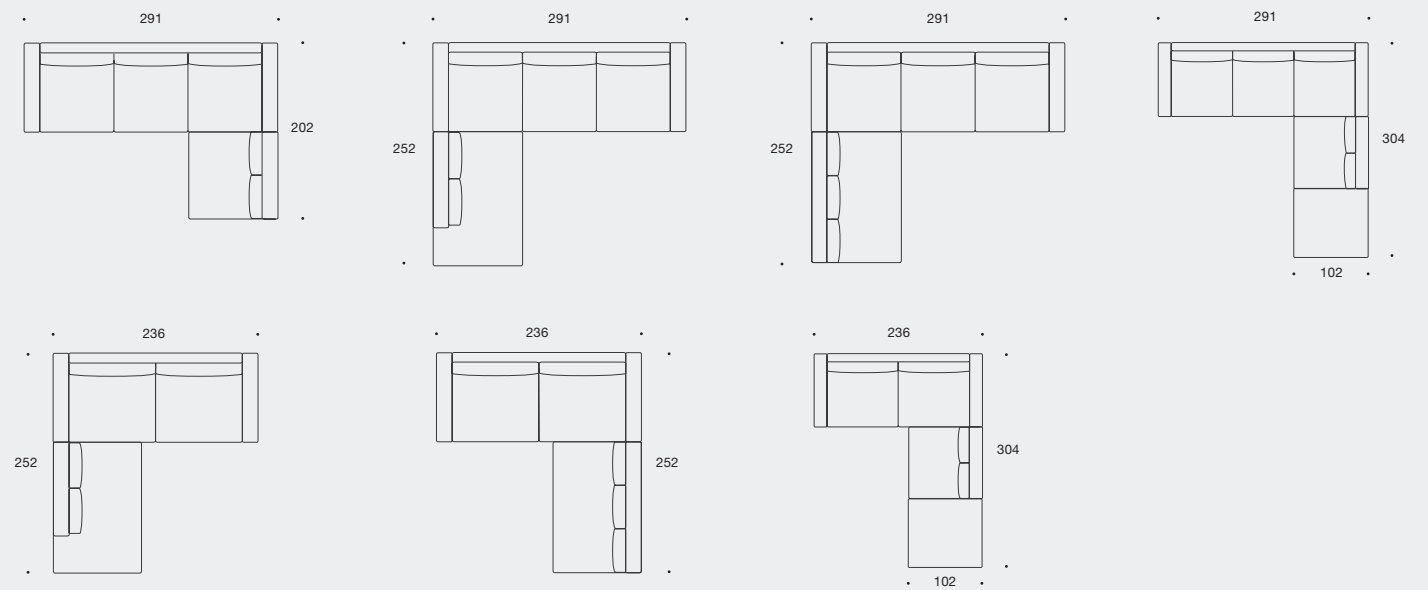



eduard

Braccioli obliqui e sedute sagomate danno un taglio diverso al design.

Eduard non si accontenta delle solite forme, ma può creare composizioni dinamiche adatte ad interiors moderni.

Un divano che ama mettersi al centro dell'attenzione e che trasforma lo spazio circostante con soluzioni di tendenza.

Oblique armrests and shaped seating give a different slant to this design. Standard shapes are not enough with the Eduard sofa, which creates dynamic compositions suited to modern interiors. This sofa loves to be the centre of attention, and transforms the surrounding space with on-trend solutions.



eduard
comp. 36



eduard
comp. 21



Doppio cuscino per rendere ancora più confortevole il relax.
The double cushion design makes relaxing even more comfortable.



eduard

Tanti singoli moduli danno forma a numerose composizioni. In particolare, le isole dalle linee svasate e irregolari esprimono un diverso linguaggio del design.

Lots of single elements give life to so many compositions. In particular, the flared irregular-shaped chaise ends speak a different language of design.



eduard
divano 3 posti/ three-seater sofa

Divan Sofas

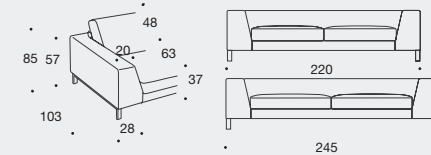

Elementi centrali Central elements

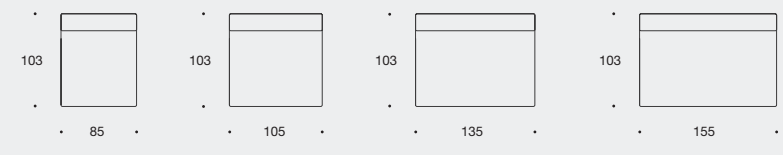

Elementi laterali Lateral elements

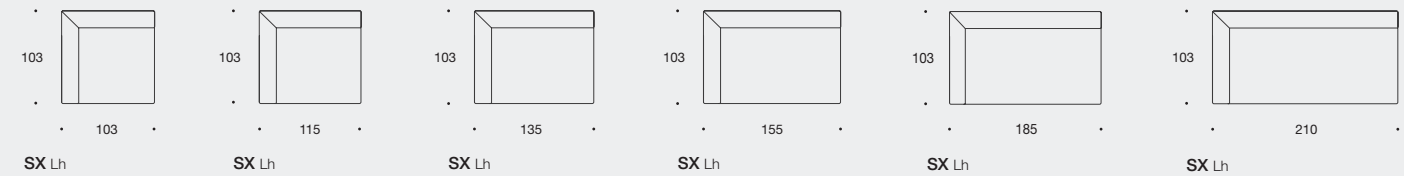

Penisole Peninsulas

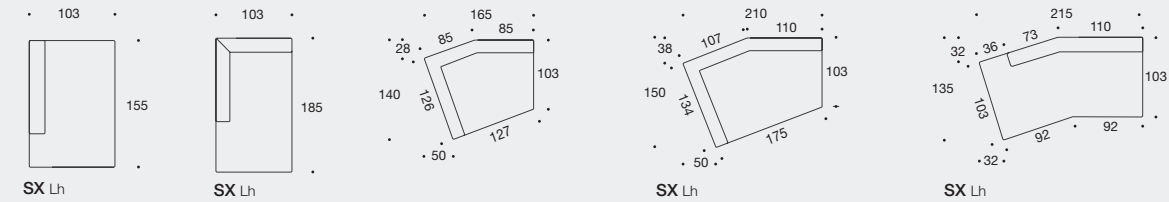

Chaise longue Chaise longue

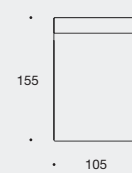

Pouf Poufs



Cuscini Cushions

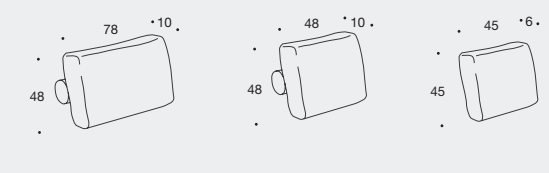

Composizione divani Sofas composition

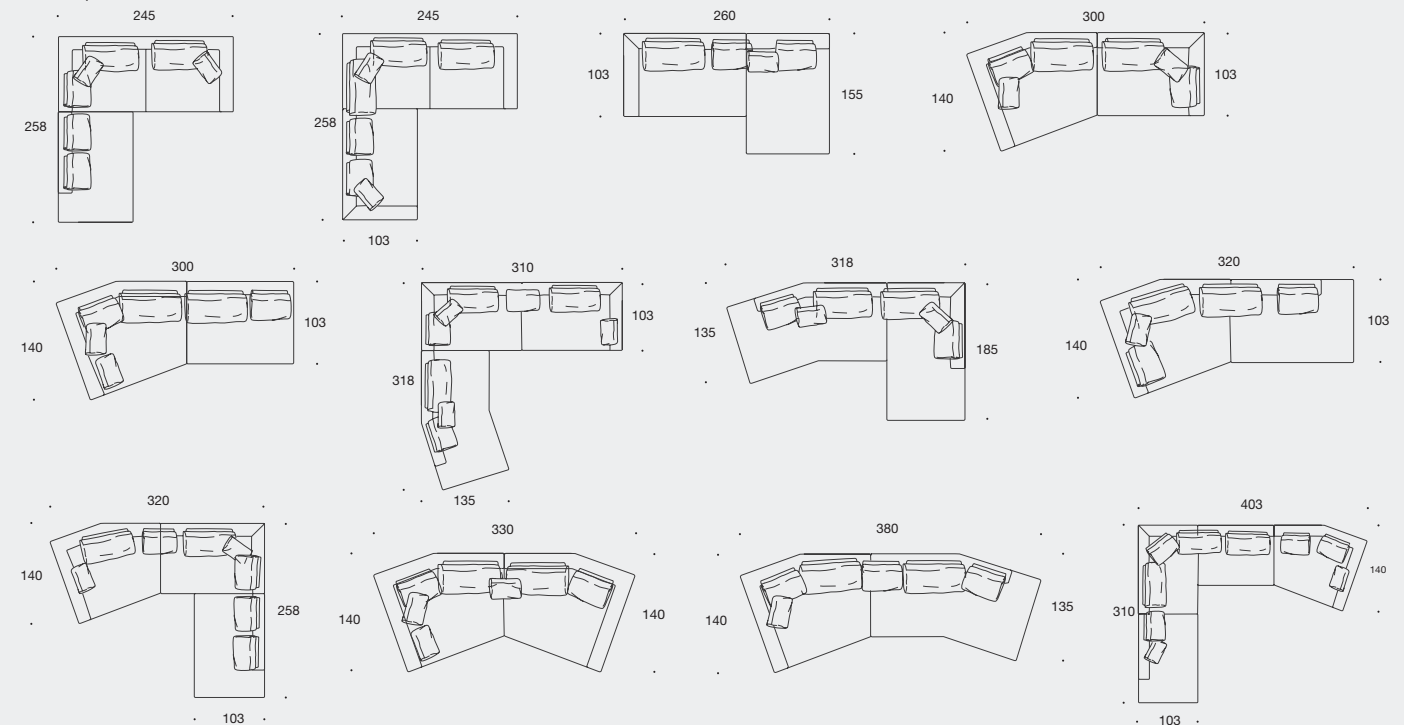

james

Un divano con i piedi per terra, saldo nella struttura e abbondante nelle forme. James ha un temperamento forte e deciso, ma allo stesso tempo accogliente e avvolgente. Il bracciolo largo e svasato unisce lo schienale alla base in una struttura voluminosa e dalla presenza scultorea. Con James la comodità è maxi.

This sofa has its feet firmly on the ground, with a solid structure and generous proportions. The James sofa has a strong and decisive temperament, but is inviting at the same time. The wide, slanted armrest brings together the backrest and the base structure into a single, sculpted unit. With the James sofa, comfort is maxi.





james
comp. 4



james
comp. 2



Una bordatura a contrasto o tono su tono disegna con delicatezza i profili di James. Contrasting or tone-on-tone piping delicately marks out the profile of the James sofa.

james
comp. 2

isa
poltroncina/
armchair

james

La modularità di James è caratterizzata da versioni lineari o integrate a penisole e chaise longue, disponibili anche in formato maxi. Per rilassarsi senza limiti.

The James sofa is modular and comes in linear models or integrated with chaise longues and chaise ends, which are also available in maxi format. Limitless relaxation.



james
divano 3 posti/ three-seater sofa

Poltrone / Divani Armachairs / Sofas

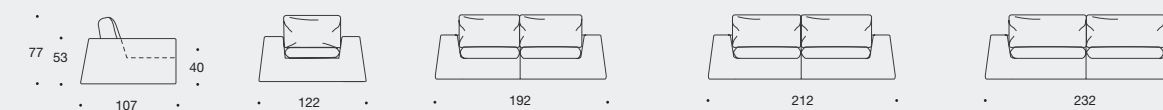

Elementi laterali Lateral elements

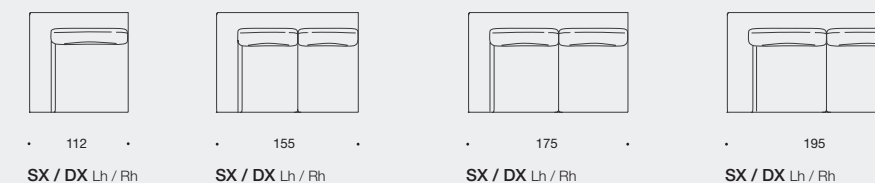

Chaise longue Chaise longue

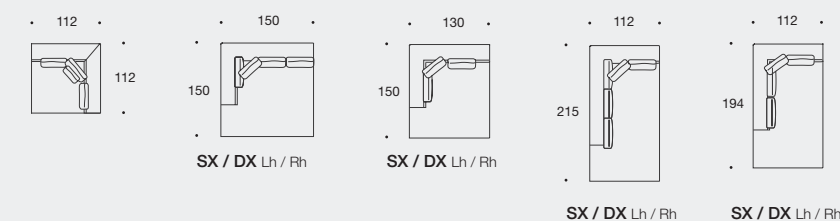

Cuscini Cushions



Composizioni divani Sofas composition

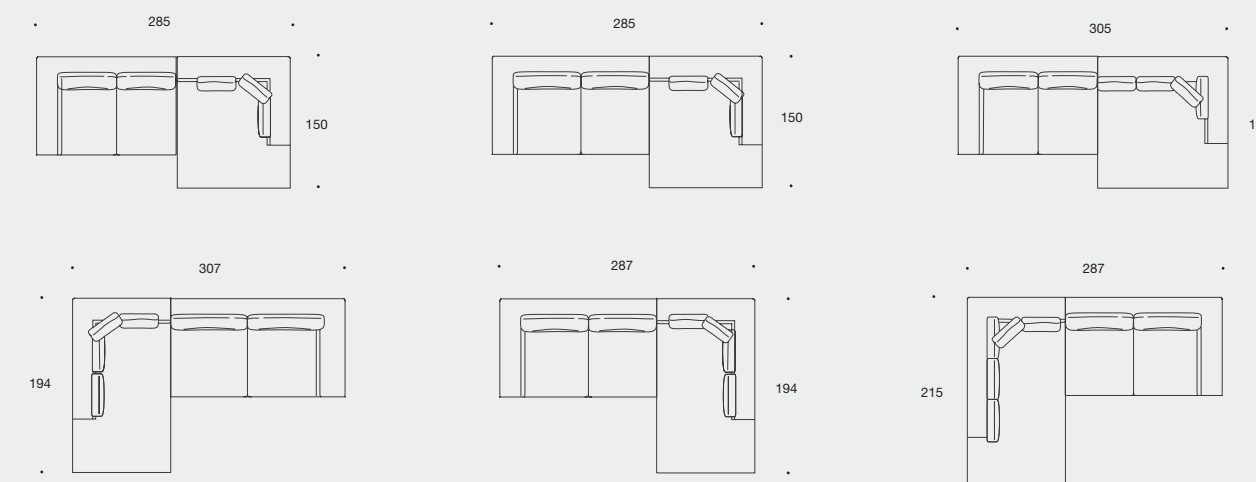

wall

Più che un divano sembra un maxi-cuscino senza sovrastrutture, dall'aria disinvolta e spontanea. Ogni pezzo può stare da solo o condividere lo spazio con altri moduli affiancati. Lo schienale è disponibile alto o basso, ma in entrambi i casi Wall mantiene il suo carattere easy, indicato per ambienti "no stress".

More like a maxi-cushion than a sofa, this model has no structural frame, just a casual, natural feel. Each element can be stand-alone, or share the space with other units alongside. The backrest is available in a high or low model, but in both cases Wall seating is relaxed and ideal for stress-free environments.





wall alto
poltroncina/ armchair
cm 137



wall basso
poltroncina/
armchair
cm 107

wall alto
poltroncina/
armchair
cm 137



Wall Alto

poltroncina/ armchair
cm 137



Wall Basso

poltroncina/ armchair
cm 137

Due diverse altezze di schienale
per vivere comodamente.
Two different backrest heights,
for comfy living.





Ritrovare del tempo per sé sulla
chaise longue stand-alone.
Find time for you, on the stand-alone
chaise longue.



wall basso
chaise longue
cm 107

wall alto

Da solo è una poltrona, in coppia o in gruppo Wall diventa un divano. Con lo schienale alto 110 cm assicura un comodo appoggio di testa e schiena.

Alone it stands as an armchair; in a pair or group it turns into a sofa. With a 110 cm-high backrest, Wall guarantees a comfortable place to rest your head and back.



wall alto
lateral/ lateral cm 137

wall basso

La comodità rimane immutata, la differenza è nello schienale con altezza 85 cm.

The level of comfort is still the same, the difference is in the backrest, at 85 cm.



wall basso
comp.

Poltrone Armchairs

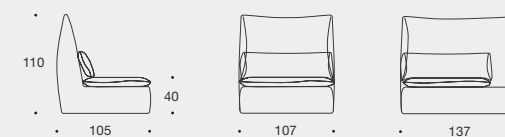

Wall alto High Wall



Wall basso Low Wall

Elementi laterali Lateral elements

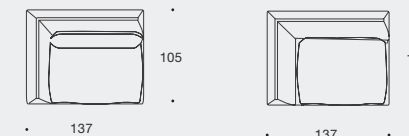

SX Lh

SX Lh

Chaise longue Chaise longue

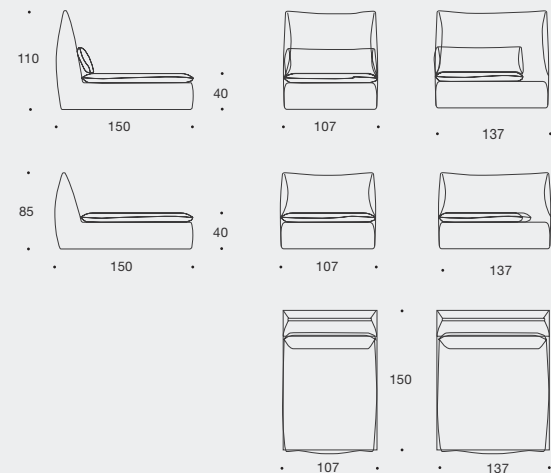

Pouf Pouf

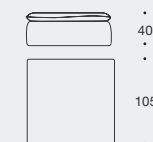

Cuscini Cushions



artur

Forme più classiche reinterpretate con modernità sono le caratteristiche principali di Artur. I braccioli arrotondati formano un tutt'uno con lo schienale, che sottolinea la struttura con un tratto morbido. Bordi in rilievo, a contrasto o uguali al rivestimento, sono realizzati da sapienti mani artigiane per decorare il design.

More traditional shapes are reinterpreted in a modern key to create the main features of Artur. The rounded armrests create one unit with the backrest, outlining the structure with a soft edge. The piping in a contrasting colour, or to match the upholstery, has been crafted by knowing hands to decorate this sofa.





artur
divano 3 posti/
three-seater sofa



Linee rotonde che si inseriscono perfettamente in atmosfere moderne.
The round lines blend perfectly into modern spaces.





artur
comp. 2

artur

Lo spirito classicheggiante di Artur si declina in modelli singoli, composti o angolari per inserirsi in tutte le tipologie di ambienti e portare ovunque il suo stile.

The classical-style spirit of the Artur sofa features in single-unit models, compositions or corner set-ups, to fit into all types of space, taking its style wherever it goes.



artur
divano medio/ sofa medium

Poltrone / Divani Armchairs / Sofas



Elementi laterali Lateral elements

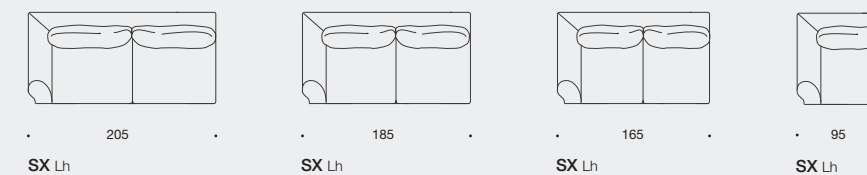

Penisole Peninsulas

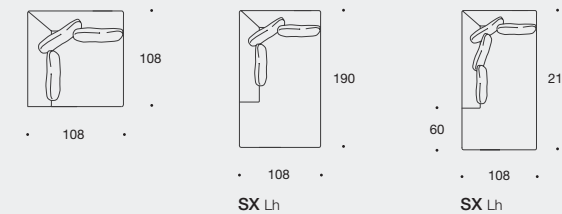

Pouf Poufs

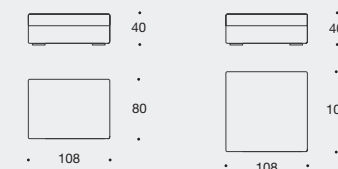

Cuscini Cushions



Composizione divani Sofas composition

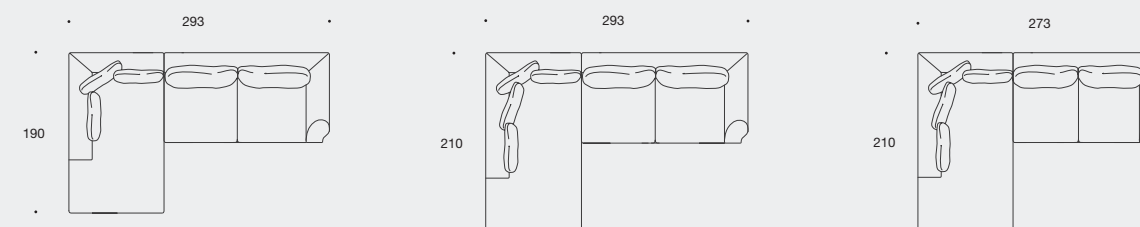



holly

Compatta nel disegno, ma generosa nelle proporzioni, Holly si compone di una struttura in legno di noce che, con i suoi tratti solidi ma delicati, raccoglie e abbraccia le rigorose geometrie dei cuscini e i loro molteplici rivestimenti.

With a compact design but generous proportions, the Holly chair is composed of a wooden walnut structure which, with its solid yet delicate form, surrounds and embraces the well-defined cushions in their various different types of upholstery.



demetra

Un salto indietro nel tempo: Demetra interpreta lo stile anni '70 con il suo design molto geometrico e il rivestimento in pied-de-poule. Perfetta per ambienti di oggi che amano le proporzioni e la comodità di ieri.

A step back in time: Demetra adopts '70s style with its geometric design and houndstooth upholstery. Perfect for the spaces of today that crave the proportions and comfort of the past.

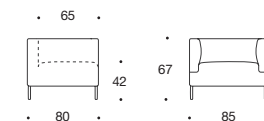



elle

Il profilo curvilineo della seduta ricorda il tratto di un sorriso. Elle è una poltrona dall'animo femminile, in equilibrio tra gusto estetico e senso pratico, morbida e decisa allo stesso tempo, indipendente ma anche legata agli altri arredi.

The curved seat profile evokes the shape of a smile. Elle is an armchair with a feminine feel, a balance between aesthetic taste and practicality, soft yet bold, independent yet tied to other elements of furniture.

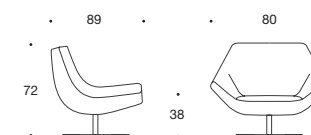

gas

Schienale e braccioli alla stessa altezza per una poltrona molto rigorosa, ma indubbiamente comoda. Il cuscino aggiunge un tocco di morbidezza alle forme e di stile al comfort. Gas è la poltrona sempre al passo con i tempi.

The backrest and armrests sit at the same height, to create a well-defined armchair that is sure to be comfortable. The cushion adds a soft touch to the shape, and style to comfort. Gas is the armchair that is always on trend.

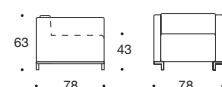



isa

Una poltrona dalla forma sagomata ed accogliente, dall'aspetto semplice ed elegante. Le cuciture disegnano la silhouette di Isa, le linee la caratterizzano, i rivestimenti la adattano agli stili d'arredo. Isa sta bene ovunque.

This chair with a shaped seat is inviting in its simple and elegant design. The stitching marks out the silhouette of the Isa chair, its lines are what distinguishes it, and the upholstery adapts it to your furnishing style. Isa fits in well anywhere.

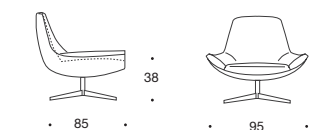



lea

Uno schienale arcuato avvolge la seduta e trasforma la poltrona in una piccola isola di quiete e relax. Lea entra negli ambienti con tonalità chiare oppure con un guizzo di colore, interpretando tutti i gusti e gli stili con la sua varietà di finiture.

The curved backrest wraps around the seat cushion and turns this chair into a little island of calm and relaxation. Lea comes into your home in pale shades or splashes of bright colour, capable of interpreting all tastes and styles with its variety of finishes.

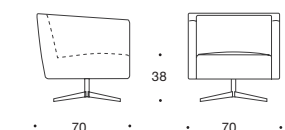

pouf

Multiuso e versatili, i pouf sono elementi irrinunciabili per completare l'ambiente e il comfort. Come semplici arredi decorativi, come prolungamento del relax, come piani di appoggio, come sedute dal carattere easy, i pouf sono perfetti accanto al divano, davanti alla tv e in qualsiasi altro posto ci sia bisogno di comodità.

Both multi-functional and versatile, this pouf is a must-have to complete the room and comfort experience. As a simple, decorative piece of furniture, an extension of relaxation, a surface to rest on or a relaxed place to sit, the pouf goes perfectly alongside a sofa, in front of the TV, or in any other place you need extra comfort.



Valentini srl

Via Pontarola, 49
35011 Campodarsego (PD) Italy
T. +39.049.9200982
F. +39.049.9200979
info@valentini.it